

theben**EN Presence detector****theRonda P360-110 DALI UP WH**

2080040

theRonda S360-110 DALI UP WH

2080580

DALI 2307279 05
22.04.2026

1. Product characteristics

- Passive infrared presence detector for ceiling installation
- Round detection area 360° (up to 50 m² or 452 m²) for reliable and easy planning
- Restriction of detection area with cover clips
- Automatic lighting control with constant lighting control or switching operation
- Lighting dimmable in switching operation with or without effect of daylight
- Orientation light (standby function)
- Easy to start-up without programming group addresses (DALI Broadcast)
- DALI-2 certified
- Mixed light measurement suitable for fluorescent lamps (FL/PL/ESL), halogen/incandescent lamps and LEDs
- Calibration of brightness measurement
- Fully or semi-automatic operation, switchable
- Brightness setpoint value adjustable in lux
- Teach-in function via remote control or button
- Self-learning time delay
- Reduction of time delay when present briefly (short-term presence)
- Detection sensitivity configurable
- 1 presence channel for external DALI relay, e.g. for HVAC control
- Connection option for buttons for manual dimming and switching
- Behaviour upon button operation selectable
- Scene functionality
- Ready for immediate use due to factory presetting
- Easy configuration of the energy-saving response with "eco plus" function
- Test mode for checking function and detection area and the constant light control
- Extension of detection area via Master/Slave or Master/Master switching
- Protection rating IP 54 (installed)
- Ceiling installation in flush-mounted box
- Surface mounting on ceilings possible with back box (option)
- Management remote control theSenda B with app theSenda Plug (optional)
- Installation remote control theSenda P (option)
- User remote control theSenda S (option)

2. Safety



Assembly and installation should only be carried out by a qualified electrician, somebody who has completed appropriate professional training and has the knowledge and experience necessary to be able to recognise and avoid the potential dangers posed by electricity.



Before installation/disassembly, disconnect the power supply and ensure that the parts are no longer live.



Prior to commissioning and using the product, read the entire manual and follow the instructions.

3. Proper use

The presence detector is intended for installation indoors and controls the lighting.

4. Function

The presence detector is primarily used in offices, schools, conference rooms and corridors, as well as in homes, for easy and energy-efficient control of lighting. The lighting is accordingly influenced by switching or constant lighting control.

Function description

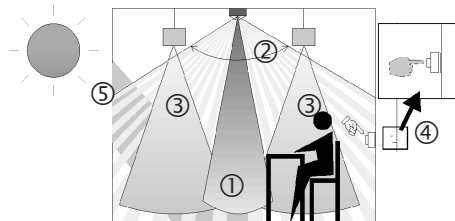

- ① Mixed light measurement
- ② Presence detection
- ③ Artificial light
- ④ Push button for manual lighting control
- ⑤ Incident daylight

Channel C1 light

The lighting is controlled by presence and brightness. Artificial lighting is switched on and regulated at a constant brightness level via the DALI interface in the event of too little daylight and when the room is occupied.

The lighting is switched off via the DALI interface if there is sufficient daylight or if the room is unoccupied.

Constant light control

Constant lighting control compensates for variations in daylight by controlling the lighting. The overall brightness will be kept constant at the desired brightness level. The lighting is switched on with the switch-on dimming value C1 and controlled so that it reaches the set brightness setpoint value C1. Depending on "school" or "office" configuration type, the presence detector behaves differently after manual dimming via button:

- "School" configuration type for applications in classrooms and meeting rooms:
 - Manual dimming stops constant lighting control.
 - Lighting remains at dimmed level when room is occupied (no brightness influence).
 - Switching off and on returns to standard operation.
- "Office" configuration type for applications in small and large offices:
 - Constant light control remains active temporarily after manual dimming to the current brightness value as the new brightness setpoint value.
 - The new brightness setpoint value only applies if the room is occupied.
 - After the lighting time delay expires, the originally set brightness setpoint value is restored.

Switching operation

Switching response is controlled by presence and brightness. The channel C1 Light switches on in darkness and if presence is detected. The light switches off when there is sufficient brightness or once the room is vacated after the set lighting time delay. The lighting is switched on with the switch-on dimming value C1. By using the button, the intensity of artificial light can be changed for the duration of the presence. The light is forced off after a preset time delay if the room was (previously) vacated.

Standby (orientation light)

The standby function acts as an orientation light. After the lighting time delay expires, the lighting is set to the standby dimming value (1 – 100%) of the lamp output. The standby time can be set between 0 s and 4 h or permanently. The lighting is switched off if the brightness level in the room exceeds the brightness setpoint value. The lighting automatically returns to the standby brightness if the room brightness falls below the brightness setpoint value. When the room is entered again, the detector returns to the programmed brightness setpoint value, either automatically (fully automatic device) or after the button is operated (semi-automatic device).

Lighting time delay

The minimum time delay (10 s – 4 h) is adjustable. It adjusts automatically to the user's behaviour and can increase to 30 minutes or reduce back to the set minimum time. With settings ≤ 2 min or ≥ 30 min, the time delay remains unchanged at the set value. If someone goes into an unoccupied room only briefly and leaves it within 30 seconds, then the light will be switched off prematurely after 2 minutes (short-term presence).

Push button control

The lighting can be manually switched or dimmed at any time via a button. A short press of the button switches the light on or off, a longer press of the button dims the lighting up or down. The dimming direction changes each time the button is pressed.

The lighting is forced off after a preset time delay if the room was (previously) vacated. If the lighting is switched off manually, the lighting remains switched off as long as the room is occupied. The lighting switches on again automatically after the time delay has expired.

Fully or semi-automatic device

Lighting control via the presence detector operates fully automatically for increased comfort or semi-automatically for greater energy savings. The lighting switches on and

off automatically as a "fully automatic device". As a "semi-automatic device", the lighting must always be switched on manually. The lighting is switched off automatically.

Exceptionally easy configuration of the energy-saving behaviour

By using the selection "eco" for optimal switching behaviour or "eco plus" for maximum energy savings, users can adjust the presence detector to their needs.

5. Detection area

theRonda S360-110 DALI

The circular detection area of the Ronda S presence detector covers an average detection area.

- ① Note that seated persons are detected in different sized areas.

The recommended installation height is 2 m – 4 m. As installation height increases, the sensitivity of the presence detector decreases. The extent and distance between the active and passive zones of the presence detector also increases. At an installation height of 3 m or higher, walking motions are necessary and the detection areas of several detectors should overlap in the marginal zones. The detection range is reduced as the temperature increases.

Seated people

The presence detector reacts very sensitively to the slightest movements. The information refers to table height (approx. 0.80 m).

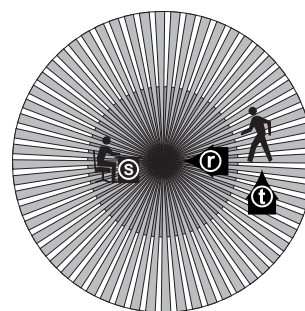
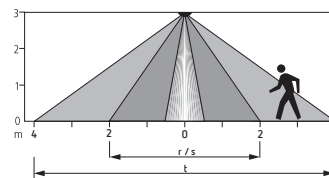

Installation height (A)	Moving persons Across (t)		Moving persons Frontal (r)		Seated persons (s)	
	Area (m²)	Radius (m)	Area (m²)	Radius (m)	Area (m²)	Radius (m)
2,0 m	38 m²	Ø 7 m	5 m²	Ø 2,5 m	5 m²	Ø 2,5 m
2,5 m	38 m²	Ø 7 m	7 m²	Ø 3 m	7 m²	Ø 3 m
3,0 m	50 m²	Ø 8 m	13 m²	Ø 4 m	13 m²	Ø 4 m
3,5 m	50 m²	Ø 8 m	13 m²	Ø 4 m	–	–
4,0 m	64 m²	Ø 9 m	13 m²	Ø 4 m	–	–

All figures are guidance value (Detection areas according to sensNORM IEC 63180, see data sheet).

theRonda P360-110 DALI

The circular detection area of theRonda P presence detector covers a large detection area, and permits a complete room coverage with many applications.

- ① Note that seated and walking persons are detected in different areas.

The recommended installation height is 2 m – 6 m. As installation height increases, the sensitivity of the presence detector decreases. Walking motions are necessary from installation heights of 3.5 m, and the detection areas of several detectors should overlap in the marginal zones. The detection range is reduced as the temperature increases.

Seated persons:

The presence detector reacts very sensitively to the slightest movements. The information refers to table height (approx. 0.80 m).

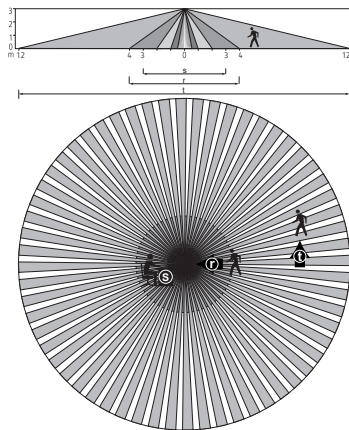

Installation height (A)	Moving persons Across (t)		Moving persons Frontal (r)		Seated persons (s)	
	Area	Radius	Area	Radius	Area	Radius
2,0 m	380 m ²	∅ 22 m	28 m ²	∅ 6 m	16 m ²	∅ 4,5 m
2,5 m	415 m ²	∅ 23 m	38 m ²	∅ 7 m	24 m ²	∅ 5,5 m
3,0 m	452 m ²	∅ 24 m	50 m ²	∅ 8 m	28 m ²	∅ 6 m
3,5 m	452 m ²	∅ 24 m	50 m ²	∅ 8 m	38 m ²	∅ 7 m
4,0 m	452 m ²	∅ 24 m	50 m ²	∅ 8 m	–	–
5,0 m	452 m ²	∅ 24 m	50 m ²	∅ 8 m	–	–
6,0 m	452 m ²	∅ 24 m	50 m ²	∅ 8 m	–	–
10,0 m	491 m ²	∅ 25 m	50 m ²	∅ 8 m	–	–

All figures are guidance value (Detection areas according to sensNORM IEC 63180, see data sheet).

Brightness measurement

The presence detector measures artificial lighting and daylight. The installation location is the reference point for the lighting level. The brightness measurement can be adapted to the conditions in a room with the room correction factor. The light measurement area maps a rectangle of about 2.0 x 3.5 m at table height.

Direct light influences the light measurement. Avoid placing floor lamps or suspended lighting directly below the detector.

- ① If the brightness measurement is deactivated, channel C1 light only switches depending on the presence (brightness setpoint value set to "measurement off" via the remote control).

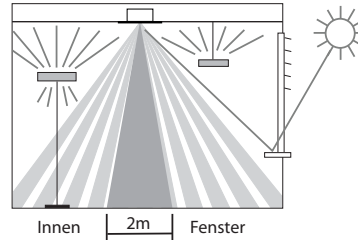

Suitable lamps

The presence detector is designed for the operation of fluorescent lamps, compact fluorescent lamps, halogen/incandescent lamps and LEDs.

6. Installation

Flush-mounted fitting

The presence detector is flush-mounted using a size 1 standard flush-mounting installation socket.

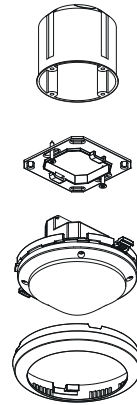

Ceiling installation

A ceiling installation box 73A is available for a simplified ceiling installation of the presence detector (see accessories). This also ensures cord grip and contact protection. The installation diameter is 72 mm (drill diameter 73 mm).

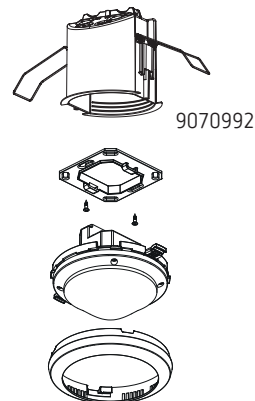

Surface-mounted installation

A back box 110A is available for surface mounted installation (see accessories).

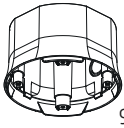

9070912

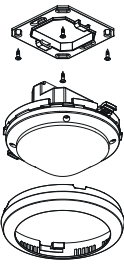

7. Connection

The presence detectors can be combined as master in individual switching, master-master in parallel switching or master-slave parallel switching. Several push buttons can be connected to one control input.

- ① Illuminated push buttons can only be used with neutral conductor connection.

Up to 50 DALI operating devices can be connected to each master device. We recommend distributing the DALI operating devices equally over the 3 phases.

- ① All detectors and buttons must be connected to the same phase.
- ① Connect at least 1 Dali operating device per master.

Individual switching

In individual switching, the presence detector, as Master, detects presence and brightness and controls lighting.

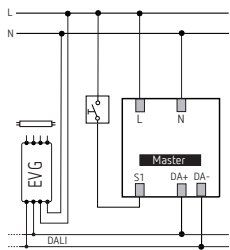

Master/Slave parallel switching

If the detection area covered by one presence detector is insufficient (larger rooms), then up to 10 detectors can be operated in parallel by connecting the P terminals. In the process, presence detection is performed by all detectors together. The Master measures the brightness, operates the buttons and controls the lighting. All other detectors are used as Slaves. They only provide presence information.

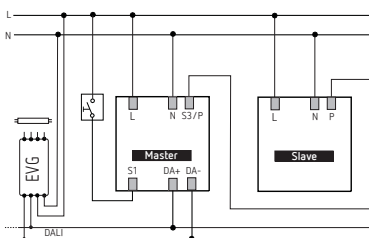

- Light measurement only with the Master
- Switch up to 10 detectors in parallel
- Use the same phase for all detectors and buttons
- Slave: theRonda P360 Slave (2080030)

Master/Master parallel switching

Several Masters can be used in parallel switching. Each Master controls its lighting group according to its own brightness measurements. Time delays and brightness setpoint values are set individually on each master. Presence continues to be detected by all detectors.

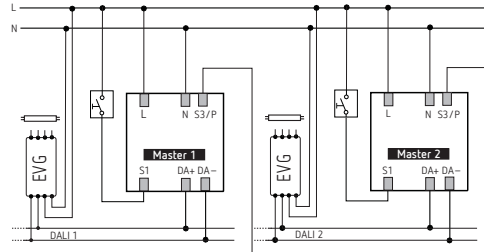

- One master with individual brightness measurement per lighting group
- Switch up to 10 detectors in parallel
- Use the same phase for all detectors and buttons

Integrating an external DALI relay

- No more than 1 external DALI relay can be connected on one single DALI line. The Dali relay must comply with Standard IEC 62386-208 (device type 7).
- The detector automatically detects the DALI relay.
- Switch-on delay and time delay can be set using the remote control.

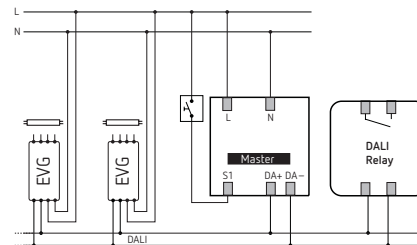

8. Settings

The presence detectors are supplied with basic settings ready for operation. The specifications are guidance values. The optional theSenda B/App remote control or the theSenda P installation remote control are available for start-up support. They enable remote setting.

The theSenda B/App can be used to query, adjust and optimise parameters. Parameters can only be adjusted with the theSenda P. In this sense, the remote controls serve as set-up aids. A range of variable parameters is available for adjustment with the remote control (see section "Parameters via remote control").

Settings via the button

Pressing the button for longer than 15 s triggers the teach-in of the brightness setpoint value by the teach-in function. In

addition, the teach-in function can be conveniently executed with the theSenda B/App remote control or the theSenda P installation remote control (see section “Control commands via remote control”).

The teach-in function via the button can be disabled using the theSenda B/App remote control when the “Configuration button” parameter is set to “disabled”.

Parameters via remote control

The following parameters can be queried or changed via the remote control for support during start-up as well as servicing:

Parameter	Description	theSenda Plug		theSenda P
		Can be queried	Can be changed	Can be changed
Function C1	Selection: switching/control	x	x	
Brightness set point value C1	Value range in lux/measurement off	x	x	x
Brightness actual value C1	Query brightness actual value	x		
Room correction factor mid	Room correction factor	x	x	
Brightness measurement value mid	Lux meter brightness value in lux		x	
Detection sensitivity (PIR)	Value range in increments	x	x	x
Lighting time delay	Value range in seconds and minutes		x	x
Short presence	Short-term presence: On/Off	x	x	
Energy saving mode	Selection: eco/eco plus	x	x	
Presence switch-on delay	Value range in seconds/minutes		x	
Presence time delay	Value range in seconds/minutes		x	x
Switch-on dimming value C1	Value range in %		x	
Configuration type C1	Selection: auto/man	x	x	x
Control speed	Selection: standard/medium/fast		x	
Minimum dimming value	Value range in %		x	
Maximum dimming value	Value range in %		x	
Switch off brightness	Value range in minutes/hours/never off		x	
Dimming speed man. dimming	Standard		x	
Manual dimming response	Selection: school/office		x	
Standby time	Value range in seconds/minutes/permanently on		x	
Standby dimming value	Value range in %		x	
IR group address C1	Selection: all or single I–VIII		x	
Scene 1 C1	Value range in %		x	
Scene 2 C1	Value range in %		x	
Configuration button	Selection: enabled / disabled		x	
LED display motion	Off/On		x	

The parameters are sent to the presence detector with the theSenda B/App remote control or with the theSenda P remote control via infra-red. Changed parameters are applied and used by the detector.

With the theSenda B/App remote control, parameters can be queried by sending values level-by-level to the detector. If the sent value is below the set parameter, the LED illuminates briefly. If the sent value is equal or above the set parameter, the LED flickers for 2 s.

Function C1

The channel C1 light can be operated in the switching operation or constant lighting control function. Settings are made via the “Function C1” parameter.

Value range (with theSenda B/App)



Switching	Channel C1 light is in the switching operating function
Control	Channel C1 light is in the constant lighting control function

Further information can be found in the section “4. Function”, under the “Channel C1 light” section on page 1.

Brightness set point value C1

The brightness setpoint value defines the minimum required brightness. The currently prevailing brightness is measured below the presence detector. If the prevailing brightness is below the setpoint value, the light is switched on when a presence is detected (in configuration type fully automatic device).

Value range

- Lux values with theSenda B/App remote control: 10 – 3000 lux, measuring off
- The following values are available with the theSenda P remote control: 10, 15, 300, 500, 800 lux, measuring off (⊛ button)
- The currently measured brightness value (lux) can be adopted as a new brightness setpoint value with the theSenda B/App remote control by using the teach-in control command, or with the theSenda P remote control via the teach-in  button. Values outside the permitted range will automatically be set to the appropriate limit value.
- Deactivation of the brightness measurement (the brightness has no effect). The light channels only switch after presence/absence. Possible with the theSenda B/App remote control (measuring off) or the theSenda P remote control (button .

Room correction factor mid, brightness measurement value mid

The room correction factor is a measurement for the difference of the brightness measurement on the ceiling and the work area. The brightness value on the ceiling is influenced by the installation location, the incidence of light, the position of the sun, the weather conditions, as well as the reflection properties of the room and the furniture.

With the room correction factor, the measured brightness value of the channel C1 light is adjusted to the conditions in the room and in this way can be matched to the lux meter value ① measured at the surface beneath the presence detector.

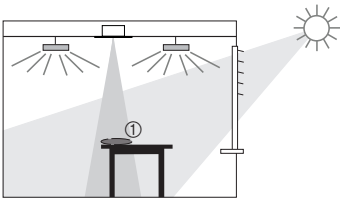

$$\text{Room correction factor} = \frac{\text{Brightness value at the ceiling}}{\text{Brightness value on the work surface}}$$



We recommend the following procedure:

- The lux meter is placed on the work surface below the sensor and the measured lux value is entered via the theSenda B/App remote control, <brightness measurement value mid> parameter.
- The room correction factor is calculated from this automatically. Values between 0.05 and 2.0 are permitted. Calculated or entered values outside the permitted range will automatically be set to the appropriate limit value.
- The calculated room correction factor will be applied immediately. For monitoring purposes, the room correction factor can be queried via the <room correction factor mid> parameter.

- ① The standard value is 0.3 and is suitable for most applications. Changes are only sensible in strongly deviating situations.

Detection sensitivity

The detector has 5 sensitivity increments. The basic setting is the middle increment (3).

Increments 1 to 5 can be selected and sent to the detector with the theSenda B/App remote control. On the theSenda P remote control, the sensitivity can be decreased by one increment each time the button  is pushed or increased with the  button.

Value range



Increment	Sensitivity
1	Very insensitive
2	Insensitive
3	Standard
4	Sensitive
5	Very sensitive

By selecting the test presence operating mode, the set sensitivity increment is not changed.

Lighting time delay

Value range

Adjustable values with theSenda B/App remote control	10 s – 4 h
--	------------

In the theSenda P remote control, the following values are available	10 s (button ) 30 s, 60 s, 2 min, 10 min, 20 min, 60 min (button )
--	---

Short presence

If someone goes into an unoccupied room only briefly and leaves it within 30 seconds, then the lighting will be switched off prematurely after 2 minutes (short-term presence). The short-term presence can be used for the fully automatic and semi-automatic configuration types.

The time delay is applied according to the set time delay.	Off
Short-term presence is active.	On

Energy saving mode eco/eco plus

The selection of "eco" stands for optimum switching behaviour, while "eco plus" stands for maximum energy saving.

Value range (with theSenda B/App)

"eco"	The time delay adjusts to the user behaviour by self-learning. It does not drop below the set value.
"eco plus"	The set time delay remains unchanged (no self-learning effect). Faster response to brightness detection than with "eco".

Presence switch-on delay

The contact of the external DALI relay closes when someone is present regardless of the brightness and after the set switch-on delay has elapsed. Buttons and the configuration type (fully automatic device/semi-automatic device) do not affect the relay contact.

Value range (with theSenda B/app)

No switch-on delay	none
Switch-on delay	10 s – 30 min

Presence time delay

The relay contact of the external DALI relay only opens once the set time delay has elapsed in periods of absence.

Value range

Adjustable values from theSenda B/app	10 s – 4 h
Adjustable values from theSenda P	10 s, 30 s, 60 s, 2 min, 10 min, 20 min, 120 min

Switch-on dimming value C1

The lighting is switched on with the switch-on dimming value in both switching operation as well as constant light control.

Value range (with theSenda B/App)

Switch-on dimming value C1	1 – 100 %
----------------------------	-----------

Configuration type C1

Fully automatic device: the lighting switches on and off automatically. (Due to presence, absence and brightness) theSenda B/App theSenda P	Auto Button A
Semi-automatic: switching on always has to be done manually. Switching off is done automatically by the presence detector. (Due to presence or brightness) theSenda B/App theSenda P	Man Button (⏻)

Control speed

In the constant light control function, the speed of the constant light control can be set with the <control speed> parameter.

Value range (with theSenda B/App)

Response is set to its optimum level. The control happens gradually and is almost imperceptible.	Standard
The control is slightly faster.	Average
The control is fast.	Fast

Minimum/maximum dimming value

The upper and lower limits of the channel C1 light output value can be set with both the <minimum dimming value> and <maximum dimming value> parameters.

Value range (with theSenda B/App)

Minimum dimming value	1% – 100%
Maximum dimming value	1% – 100%

Switching off brightness

In the constant light control function, it is possible to choose to switch the lighting off when there is sufficient brightness. If the lighting is controlled down to the lower limit, the lighting will be switched off after the time set at the parameter <Switch off brightness>. With the selection "never off", the lighting will never be switched off. This behaviour is valid, as long as people are present.

Value range (with theSenda B/App)

Switches lighting off after a set amount of time.	5 min – 9 h
Lighting is never switched off.	Never off

Dimming speed man. dimming

The parameter <Dimming speed man. dimming> can be used to set the dimming speed via the connected push-button or theSenda S/theSenda B remote control.

Value range

Dimming takes place at normal speed.	Standard
Dimming takes place at fast speed.	fast

Manual dimming response

With constant lighting control, the manual dimming response can be selected with the <manual dimming response> parameter.

Value range (with theSenda B/App)

Constant light control remains active temporarily after manual dimming to the current brightness value as the new setpoint value. After the lighting time delay has expired, the originally configured setpoint value is restored.	Office
Constant light control is interrupted temporarily via manual dimming. The set point value remains unchanged.	School

Further information can be found in the chapter "Channel C1 light – constant lighting control" on page 2.

Standby time/standby dimming value

When standby time is activated, the lighting is not switched off after completion of the lighting time delay, but remains set to the standby dimming value as an orientation light.

Value range (with theSenda B/App)

Standby time	30 s – 4 h
Standby function (orientation light) is not active	0 s
Standby function (orientation light) is permanently switched on	On
Standby dimming value	1 – 100%

IR group address C1

This parameter is applied when using the theSenda S user remote control.

A group address can be assigned to channel C1 light. The theSenda B/App remote control or the theSenda S remote control can be used to program the group addresses in the detector.

Group address value range

Adjustable values theSenda B/App	All or single I–VII
Adjustable values theSenda S	I, II

Using the theSenda S remote control, the group addresses can be assigned as follows:

Press the ⏻1 and ⏻1 buttons simultaneously for at least 5 s	I
Press the ⏻2 and ⏻1 buttons simultaneously for at least 5 s	II



Scene 1 C1 / Scene 2 C1

The desired dimming value for channel C1 light can be allocated to scene 1 and scene 2.

Value range (with theSenda B/App)

Adjustable values	0 – 100%
-------------------	----------

Using the theSenda S/theSenda B remote control, the lighting is firstly set to a desired brightness and then saved as followed:

Press the  1 button for at least 3 s.	Scene 1 is saved
Press the  2 button for at least 3 s.	Scene 2 is saved

The scene is called up by briefly pressing the button.

Configuration button

The teach-in function via the button can be enabled or disabled with the <configuration button> parameter.

Value range (with theSenda B/App)

Teach-in function via the button can be executed.	Enabled
Teach-in function via the button is disabled.	Disabled

LED display motion

The motion detection can be displayed via the LED.

Value range (with theSenda B/App)

No display of motion detection.	Off
The LED is switched on when motion is detected, otherwise switched off.	On

Control commands via remote control

The following control commands can be triggered with the remote control:

Control command	Description	Can be triggered theSenda B/App	Can be triggered theSenda P
Switching light	Lighting group can be switched on and off.	x	x
Teach-in channel C1	Activation	x	x
Presence test	Off / On	x	x
Light test	Off / On	x	
Restart	Restart detector	x	x
Factory settings	Set all parameters and settings to factory setting.	x	
Reset DALI ECGs	All connected DALI ECGs are reset to factory settings	x	
Reset DALI relays	All connected DALI relays are reset to factory settings	x	

Teach-in channel C1

During teach-in, the currently measured brightness value is accepted as brightness setpoint value C1. Values outside the permitted range will automatically be set to the appropriate limit value. The teach-in control command can be executed with the theSenda B/App remote control or with the theSenda P remote control via the  button.

Presence test

Presence test mode is used to test presence detection and wiring. Presence test mode can be activated with the theSenda B/App remote control or with the theSenda P remote control ( button). The detector goes directly into test mode when the test mode is set:

- Every movement is indicated by the LED.
- When motion is detected, the lighting is switched on.

- The lighting is switched off after 10 seconds when the room is unoccupied.
- Brightness measurement is deactivated, detector does not respond to brightness.
- Constant light control is deactivated (switching mode).
- Standby function is deactivated.
- The detector reacts as in configuration type "fully automatic device", even if "semi-automatic" is set.
- Teach-in cannot be activated in test mode.
- Test mode ends automatically after 10 min. The detector performs a new start (see switch-on behaviour on page 10).

Light test

The light test mode is used to check the brightness threshold and the constant light control. The light test mode can be activated with the theSenda B/App remote control. The detector goes directly into test mode when the test mode is set:

- The LED shows the light test mode (5 seconds on, 0.3 seconds off).
- The presence detector responds as in normal operating mode, only the reaction to bright/dark is faster.
- In order to simulate this behaviour, either the area below the presence detector can be illuminated or the blinds operated.
- Test mode ends automatically after 10 min. The detector performs a new start (see switch-on behaviour on page 10).

 Note: Do not use a torch to switch the presence detector! The adaptive light switching thresholds will be distorted!

Factory settings

The presence detector is supplied with the following parameter values:

Parameter	Value
Function C1	Control
Brightness set point value C1	500 lux
Room correction factor mid	0.3
Detection sensitivity (PIR)	Increment 3
Lighting time delay	10 min
Short presence	On
Energy saving mode	eco
Presence switch-on delay	0 s
Presence time delay	10 min
Switch-on dimming value C1	50%
Configuration type	Auto
Control speed	Standard
Minimum dimming value	10%
Maximum dimming value	100%
Switching off brightness	10 min
Dimming speed man. dimming	Standard
Manual dimming response	School
Standby time	0 s
Standby dimming value	10%
IR group address C1	I
Scene 1 C1	30%
Scene 2 C1	70%
Configuration button	Enabled
LED display motion	Off

The parameters can only be set to factory settings by using the theSenda B/App remote control.

Resetting the DALI installation

The connected DALI devices are reset to the factory settings. The short addresses and group addresses are deleted.

Reset DALI ECGs

The connected DALI ECGs are reset to factory settings.

Resetting the DALI relay

The connected DALI relay is reset to the factory settings.

9. Start-up

Switch-on behaviour

Every time the power supply is switched on, the presence detector runs through two phases that are indicated by the LED:

1. Start-up phase (30 s)

- The red LED flashes at one second intervals and lighting is switched on with switch-on dimming value C1.
- The detector does not respond to push-button commands or to the theSenda S remote control.
- The lighting is switched off after 30 seconds when the room is unoccupied.

2. Operation

- The red LED is off. The constant light control or switching mode are started.
- The detector is ready for operation.

10. Technical data

Operating voltage	110 – 230 V AC, +10% / -15%
Frequency	50 – 60 Hz
Upstream protection device	16 A
Power consumption (without DALI-ECG)	< 0.4 W
Type of installation	Ceiling installation; flush / surface mounted or ceiling installation
theRonda S360-110 DALI recommended installation height	2.0 – 3.0 m / max. 4 m
theRonda P360-110 DALI recommended installation height	2.0 – 3.5 m / max. 15 m
Minimum height	> 1.7 m
Detection area horizontal	360°
theRonda S360-110 DALI maximum range	Ø 4 m (Mh. 3 m) / 13 m ² seated Ø 9 m (Mh. 15 m) / 64 m ² walking
theRonda P360-110 DALI maximum range	Ø 7 m (Mh. 3.5 m) / 38 m ² seated Ø 25 m (Mh. 10 m) / 491 m ² walking
Setting range brightness setpoint value	10 – 3000 lux
Lighting time delay	10 s – 4 h

Presence switch-on delay	0 s – 30 min
Presence time delay	10 s – 4 h min
Lighting standby time	0 s – 4 h / permanently on
Standby dimming value	1 – 100 %
Control output lighting	100 mA guaranteed, max. 250 mA, max. 64 DALI operating devices, basic insulation
Connection type	Screw terminals
Max. cable cross-section	Max. 2 x 2.5 mm ²
Size of flush-mounted box	Size 1, Ø 55 mm (NIS, PMI)
Protection rating	IP 20 (IP 54 installed)
Ambient temperature	-15 °C ... 50 °C
CE Declaration of Conformity	This device conforms to the safety regulations of the EMC directive 2014/30/EU and of directive 2014/35/EU.
Dali conformity	IEC 62386-101, IEC 62386-103

Cleaning and service

- Only use a dry, soft cloth to clean the device surface.
- Do not use any cleaning agents or solvents.

Disposal



Dispose of the appliance separately from domestic waste at an official collection point.

Troubleshooting

Fault	Cause
Light does not switch on and/or off if presence is detected and in darkness	Brightness setpoint value is set too low; detector set on semi-automatic; light was switched off manually via button or theSenda S; person not within detection area; obstruction(s) interrupting detection; time delay set too short
Light stays on with detection of presence despite sufficient brightness	Brightness setpoint value is set too high; light was briefly switched on manually via button or with theSenda S (wait 30 min in switching operation); detector is in test mode
Light does not switch off and/or light switches on spontaneously when no one is present	Wait for time delay (self-learning); thermal sources of interference in the detection area: fan heaters, incandescent lamps/halogen spotlights, moving objects (e.g. curtains hanging in open windows)
Push button does not function	Device still in the start-up phase; illuminated button was used without neutral conductor; push button not fed to the Master
Light cannot be switched off with the push button	Push button not fed to the detector. Check wiring to the button
Lighting does not react	Short circuit or interruption in the DALI bus. Electrical surge in the DALI bus: Disconnect the detector from the supply network for 1 minute (thermal fuse).
Device does not respond	Short-circuit: disconnect detector from the power supply for 5 min (thermal fuse)
Error flashing (4 x per second)	Error in self-test; device not properly functional!
LED is on and flashes off briefly 2 x every 3 s	Detector does not recognise DALI ECGs. Check DALI connections. At least 1 DALI ECG must be connected to the detector. Short circuit in DALI bus.
Master/Slave, Master/Master parallel switching is not working	Detectors and buttons are not connected to the same external conductor. <Terminal S3/P assignment> parameter is not set to "Parallel".

11. Dimensions diagrams

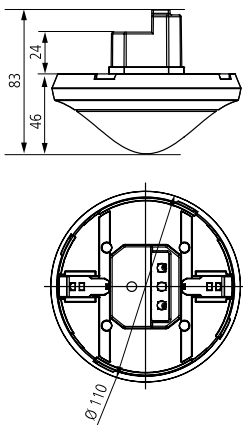

12. Accessories

Back box 110A WH

Item No.: 9070912

[Details > www.theben.de/en](http://www.theben.de/en)

Back box 110A GR

Item No.: 9070913

[Details > www.theben.de/en](http://www.theben.de/en)

DE (ceiling installation) box 73A

Item No.: 9070917

[Details > www.theben.de/en](http://www.theben.de/en)

Cover clip for area restriction

Item No.: 9070921

[Details > www.theben.de/en](http://www.theben.de/en)

theSenda P

Item No.: 9070910

[Details > www.theben.de/en](http://www.theben.de/en)

theSenda S

Item No.: 9070911

[Details > www.theben.de/en](http://www.theben.de/en)

theSenda B/App

Artikel-Nr.: 9070985

[Details > www.theben.de](http://www.theben.de)

13. Contact

Theben AG

Hohenbergstr. 32

72401 Haigerloch

GERMANY

Phone +49 7474 692-0

Fax +49 7474 692-150

Technical Support

Phone +49 7474 692-369

techsupport@theben.de

www.theben.de