



## 1. Product characteristics

- Passive infrared presence detector for ceiling installation
- Circular detection area 360° to Ø 24 m (452 m<sup>2</sup>)
- Restriction of detection area with cover clips
- Automatic presence- and brightness-dependent control for lighting and HVAC
- Mixed light measurement suitable for fluorescent lamps (FL/PL/ESL), halogen/incandescent lamps and LEDs
- Channel A light: relay, 230 V
- Choice of fully or semi-automatic operation
- Brightness switching value configurable, teach-in function
- Reduction of time delay when briefly present (short-term presence)
- Connection option for push buttons or switches for manual switching with automatic detection of push button/switch
- Pulse function for staircase light time switch
- Channel H, presence: relay, floating e.g. for HVAC control
- Switch-on delay and time delay configurable
- Detection sensitivity configurable
- Ready for immediate use due to factory presetting
- Test mode for checking function and detection area
- Extension of detection area via master/slave or master/master switching, a maximum of 10 detectors can be switched in parallel with each other
- Ceiling installation in flush-mounted box
- Ceiling installation possible with back box (optional)
- User remote control theSenda S (optional)
- Management remote control SendaPro (optional)
- Installation remote control theSenda P (optional)

## 2. Safety



Assembly and installation should only be carried out by a qualified electrician, somebody who has completed appropriate professional training and has the knowledge and experience necessary to be able to recognise and avoid the potential dangers posed by electricity.



Before installation/disassembly, disconnect the power supply and ensure that the parts are no longer live.



Prior to commissioning and using the product, read and observe all the operating instructions.

## 3. Intended use

The presence detector is intended for interior installation. The presence detector is exclusively intended for the use as contractually agreed between the manufacturer and the user. Any other use is considered to be unacceptable. The manufacturer does not accept liability for any resulting damages.

## 4. Function

The presence detector is primarily used in entrance halls, garages, store rooms, offices and schools, as well as in homes, for easy and energy-efficient control of lighting plus HVAC. The switch contact „light“ switches lighting on with presence and insufficient brightness, and off with absence or sufficient brightness. The light can also be switched on/off manually using push buttons or switches.

The „Presence“ switch contact controls heating, ventilation and air conditioning systems. The contact closes when someone is present, a switch-on delay permits delayed switch on.

### Functional description

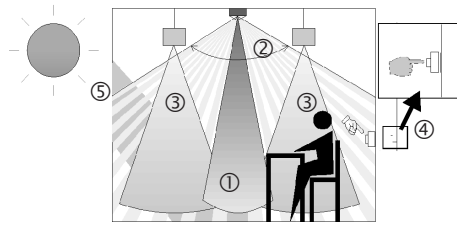

- ① Mixed light measurement
- ② Presence detection
- ③ Artificial light
- ④ Push button for manual lighting control
- ⑤ Incident daylight

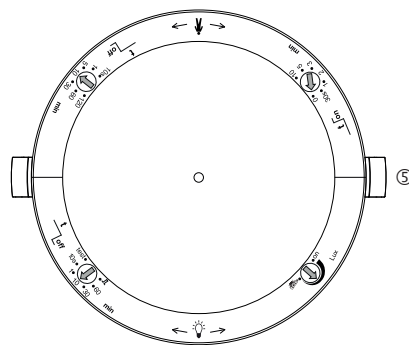

### Settings on theRonda P360-101

- ① Brightness set point value (lux)
- ② Lighting time delay
- ③ Presence time delay
- ④ Presence switch-on delay
- ⑤ Mechanical safety lock

### Light channel A

Switching response is controlled by presence and brightness. The switch contact closes during darkness and when someone is present. It opens with a delay when there is brightness or when no one is present.

### Time delay

The time delay enables delayed switching off of lighting after the room is vacated. The time delay is adjustable in a range of 10 s to 60 min. If someone goes into an unoccupied room only briefly and leaves it within 30 seconds, then the light shuts off prematurely after 2 minutes (short-term presence).

### Push button control

The lighting can be manually switched at any time via a push button or switch. If the light is switched on manually, it will remain on for at least 30 minutes providing people are present. It then switches off when the brightness is adequate. The light is forced off after a preset time delay if the room was (previously) vacated. If artificial lighting is switched off manually, the lighting remains switched off as long as the room is occupied. The lighting switches again automatically after the time delay has expired.

### Fully or semi-automatic

Lighting control via the presence detector operates fully automatically for increased comfort or semi-automatically for greater energy savings. In „fully automatic“ the lights switch on and off automatically. Light switching has to be completed manually in „semi-automatic mode“. The lighting is always switched off automatically.

### Pulse function

Time delay can be set to pulse for controlling existing staircase light timer switch. The light output produces a pulse of 0.5 seconds duration every 10 seconds if people are present or it is dark.

### Channel presence H

Channel presence H is used for HVAC control. The switching response of the floating contact is influenced only by presence and not by brightness. If the contact is closed, the time delay will be restarted at every movement. The contact is not influenced by the push button or switch.

### Switch-on delay

The switch-on delay prevents instantaneous switch on. The contact closes only on expiry of the switch-on delay, providing people are constantly present.

### Time delay

The time delay enables delayed switching off of HVAC devices and systems after the room is vacated.

## 5. Detection area

The circular detection area of the Ronda presence detector covers a large detection area, and permits a complete room coverage with many applications. Note that seated and moving persons can be detected in differently-sized areas. The recommended installation height is 2.0 m – 6.0 m. As installation height increases, the sensitivity of the presence detector decreases. Walking motions are necessary from installation heights of 3.5 m and the detection areas of several detectors should overlap in the marginal zones. The detection range is reduced as temperatures increase.

### Seated persons:

The details relate to smallest movements at table height (approx. 0.80 m).

### Moving persons:

At installation heights of between 5 and 10 m, the extent and distance between the active and passive zones increase.

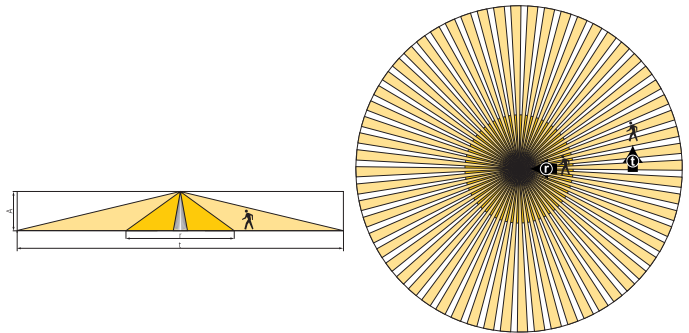

Installation height (A)	Moving persons Frontal (r)		Moving persons Across (t)		Seated persons: (s)	
	Area	Ø	Area	Ø	Area	Ø
2,0 m	28 m <sup>2</sup>	Ø 6 m	380 m <sup>2</sup>	Ø 22 m	16 m <sup>2</sup>	Ø 4,5 m
2,5 m	38 m <sup>2</sup>	Ø 7 m	415 m <sup>2</sup>	Ø 23 m	24 m <sup>2</sup>	Ø 5,5 m
3,0 m	50 m <sup>2</sup>	Ø 8 m	452 m <sup>2</sup>	Ø 24 m	28 m <sup>2</sup>	Ø 6 m
3,5 m	50 m <sup>2</sup>	Ø 8 m	452 m <sup>2</sup>	Ø 24 m	38 m <sup>2</sup>	Ø 7 m
4,0 m	50 m <sup>2</sup>	Ø 8 m	452 m <sup>2</sup>	Ø 24 m	–	–
5,0 m	50 m <sup>2</sup>	Ø 8 m	452 m <sup>2</sup>	Ø 24 m	–	–
6,0 m	50 m <sup>2</sup>	Ø 8 m	452 m <sup>2</sup>	Ø 24 m	–	–
10,0 m	50 m <sup>2</sup>	Ø 8 m	491 m <sup>2</sup>	Ø 25 m	–	–

All figures are guidance values.

### Brightness measurement

The presence detector measures artificial light and daylight that is reflected directly below the detector. The light measurement area maps a rectangle of about 2 x 3.5 m at table height. The installation location is a reference point for the lighting level. Direct light influences the light measurement. Avoid placing floor lamps or suspended lighting directly below the detector. If the brightness measurement is deactivated, the light channel A only switches depending on the presence (brightness switching value set to „on“ via potentiometer or set to „measurement off“ via the remote control).

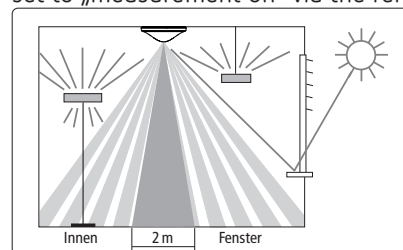

### Suitable lamps

The presence detector is designed for the operation of fluorescent lamps, compact fluorescent lamps, halogen/incandescent lamps and LEDs. The maximum number of switchable lights is restricted due to the high inrush current levels of the EBs and LED drivers. The use of an external contactor helps with large loads. Parallel switching enables allocation of load to several Masters. All switched loads must be properly suppressed.

## 6. Installation

### Flush-mounted fitting

The presence detector is flush-mounted using a size 1 standard flush-mounting installation socket.

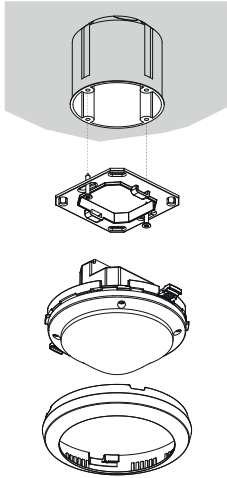

### Ceiling installation

A ceiling installation unit 73 A is available for simplified ceiling installation of the presence detector (see accessories). This also ensures cord grip and contact protection. The installation diameter is 72 mm (drill diameter 73 mm).

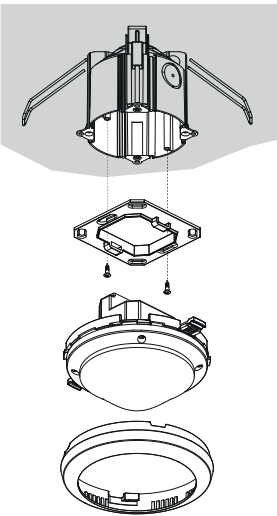

### Surface-mount installation

A back box 110A is available for surface mount installation (see accessories).

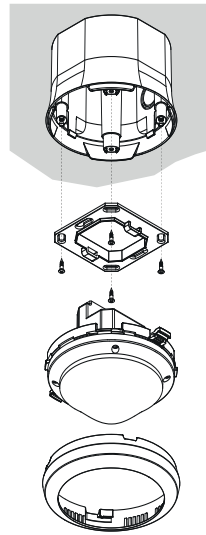

## 7. Switching

The presence detectors can be combined as master and slave: master in individual switching, master in parallel switching, master-slave parallel switching.

Several push buttons can be connected to one control input. Illuminated push buttons can only be used with neutral conductor connection.

### Individual switching

In individual switching, the presence detector as master detects presence and brightness and controls lighting.

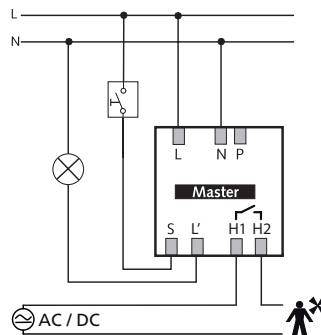

### Master/slave parallel switching

If the detection area covered by one presence detector is insufficient (larger rooms), then up to 10 detectors can be operated in parallel by connecting P terminals. In the process, presence detection is performed by all detectors together. The master measures the brightness, operates the push buttons and controls the lighting. All other detectors are used as slaves. They only provide presence information.

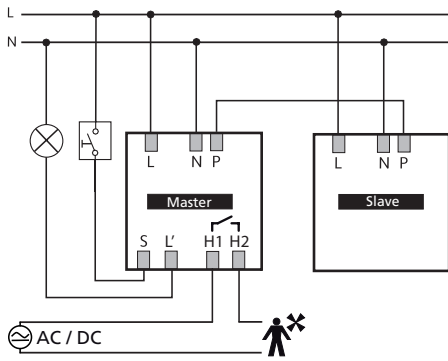

- Light measurement only with the master
- Parameters are only set on the master
- Switch up to 10 detectors in parallel
- Use the phase with the same phase for all detectors.

Master: theRonda P360 -101 M  
 Slave: theRonda P360 Slave

### Master/master parallel switching (for several lighting groups)

Several masters can be used in parallel switching setup. Each master controls its lighting group according to its own brightness measurements. Delay times and brightness switching values are set individually on each master. Presence continues to be detected by all the detectors.

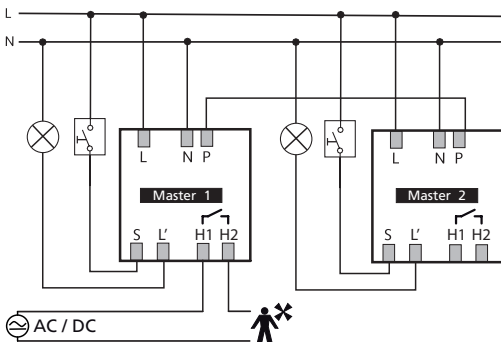

- One master with individual brightness measurement per lighting group.
- Set potentiometer individually for each master.
- Switch up to 10 detectors in parallel.
- Use the phase with the same phase for all detectors.
- The presence switch contact can be read by any master.

## 8. Settings

The presence detectors were supplied with basic settings ready for operation. The specifications are guidance values. The „SendoPro 868-A“ and „theSendaP“ remote controls are optionally available for start-up. They enable remote setting of all potentiometer values settings from a distance.  
 Switch contact light settings

### Potentiometer brightness switching value A „lux“

The required brightness switching value can be set via the lux potentiometer.

The setting range is around 30 to 1000 lux. The factory pre-setting is 300 lux.

Brightness switching values from 30 to 3000 lux can be set via the management remote control.



Teach-in : When the lux potentiometer is moved to the teach-in position, the LED start to flash for 20 seconds. As soon as the LED stops flashing, the current measured brightness value is accepted as the brightness switching value. When the teach-in position is exited, the set value on the LUX potentiometer is accepted as the new brightness switching value.

Teach-in can also be carried out using the „SendoPro 868-A“ and „theSenda P“ remote controls. In this case, the current measured brightness value is immediately accepted as the brightness switching value.

The brightness measurement is deactivated at potentiometer setting „on“. The channel light then switches only depending on presence.

### Potentiometer lighting time delay

The following guidance values have proved themselves in practice and are recommended as settings:

- Transit zones (no work area) approx. 5 min
- Classroom approx. 10 min
- Work areas (office, meeting room) approx. 10 min
- „Pulse“ : Control staircase light time switch (0.5 s „on“ / 10 s „off“)

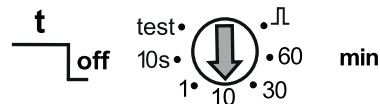

### Switch contact presence H settings

#### Potentiometer presence time delay

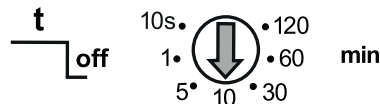

The contact closes if people are present and opens when the room is vacated after the time delay expires.

#### Potentiometer presence switch-on delay



- The contact only closes when someone is present after expiry of the switch-on delay
- 0 = contact closes immediately if people are present

## Parameters and control commands via remote control

The following parameters can be queried or changed via the remote control for support during installation as well as servicing:

Parameter	Description	SendoPro can be queried 868-A	SendoPro be changed 868-A	theSenda P can be changed
Brightness switching value A	Value range in lux	x	x	x
	Measurement off	x	x	x
Time delay A	Value ranges in seconds and minutes		x	x
	Pulse		x	x
Short presence A	On / Off		x	
Time delay H	Value ranges in seconds and minutes		x	x
Switch-on delay H	Value ranges in seconds and minutes		x	
Configuration type	auto / man	x	x	x
Control input S	Auto / switch / push button S / push button O		x	
Detection sensitivity (PIR)	Value range in levels		x	x
Group address	All / I / II / III		x	x
LED display movement	Off / On		x	

The parameters are sent to the presence detector with the „SendoPro 868-A“ management remote control or with „theSenda P“ installation remote control via infra-red. Changed parameters are immediately applied and used by the detector.

With the „SendoPro 868-A“ management remote control, parameters can be queried by sending values level-by-level to the detector. If the sent values are below the set parameter, the LED illuminates briefly. If the sent values are equal or above the set parameter, the LED flickers for 2 seconds.

### The following control commands can be triggered with the remote control:

Control command	Description	Can be triggered SendoPro 868-A	Can be triggered theSenda P
Teach-in channel A	Activate	x	x
Switch lights on/off	Lighting group can be switched on and off.	x	x
Presence test	On / Off	x	x
Restart	Restart detector	x	x
Factory regulations	Set all parameters and settings to factory setting.	x	

### Brightness switching value A

The brightness switching value defines the minimum desired brightness. The current prevailing brightness is measured below the presence detector. If the prevailing brightness is

below the switching value, the light switches on when a presence is detected (in configuration type fully automatic).

### Value range

Lux values with "SendoPro 868-A" management remote control In the installation remote control "theSenda P", the following values are available  (The currently measured brightness value (Lux) can be adopted with the "SendoPro 868-A" management remote control, with the teach-in control command or with the "theSenda P" installation remote control via the teach-in button.) Values outside the permitted range will automatically be set to the appropriate limit value.	30 - 3000 Lux 30, 300, 500, 800 lux
--	--

- Deactivating the brightness measurement (the brightness has no influence) - The light channels only switch after presence/absence. Possible with "SendoPro 868-A" management remote control or "theSenda P" installation remote control.	Measurement off  Button ☀
---	---------------------------------

### Time delay A

#### Value range

Adjustable values with "SendoPro 868-A" management remote control In the "theSenda P" installation remote control, the following values are available	10 s - 60 min 10 s, 30 s, 60 s, 2 min, 10 min, 20 min, 60 min
--	--

Control for staircase light timer switch (0.5 s "on" / 10 s "off") "SendoPro 868-A" "theSenda P"	Pulse Button 
--	---

### Short-term presence

The time delay of channel A light can be switched off sooner if a room is occupied only for a short time. (In fully automatic device and semi-automatic device configuration type)

The switch-off delay time is used according to set parameters.	Off
If someone enters an unoccupied room and it is only occupied for up to 30 seconds, the light goes off 2 minutes early.	On

### Time delay H

The presence channel always switches, regardless of whether configuration type is set to fully automatic or semi-automatic. The set values remain unchanged. The relay contact opens once the room is vacated after the set time delay expires.

#### Value range

Adjustable values "SendoPro 868-A"	10 s ... 120 min.
Adjustable values "theSenda P"	10 s, 30 s, 60 s, 2 min, 10 min, 20 min, 120 min

### Switch-on delay H

The presence channel always switches, regardless of whether configuration type is set to fully automatic device or semi-automatic device. The relay contact only closes when someone is present after expiry of the set switch-on delay.

## Value range

Adjustable values	0 s, 30 s, 1 ...10 min
No switch-on delay (relay contact closes immediately when someone is present)	0 s

Adjustment only possible with „SendoPro 868-A“.

## Configuration type

Fully automatic device: The lighting switches on and off automatically. (due to presence/no presence and brightness) „SendoPro 868-A“ „theSenda P“	auto Button A
Semi-automatic: Switch on must always occur manually. Switch off occurs automatically by the presence detector. (due to presence or brightness) „SendoPro 868-A“ „theSenda P“	man Button 

## Control input S

Control input S for manual switch on/off of channel A light automatically detects push buttons or switches. Several push buttons can be connected to control input S Use light push button only with neutral conductor connector

## Value range

Automatic detection of push button or switch. A signal that is present for than 0.7 s is detected as a push button. Longer signals are evaluated as a switch.		auto
To adapt to user behaviour, the type of signal transmitter used can be set to fixed. Automatic detection is deactivated. When selecting the push button, opening contact or NO contact can also be specified.	Switch	Switch
	Push button (NO contact)	Push button S
	Push button (opening contact)	Push button 0

Configuration possible only with „SendoPro 868-A“.

## Detection sensitivity

The detector has 5 sensitivity increments. The basic setting is the middle level (3). By selecting the operation mode test presence, the set sensitivity increment is not changed. With the „SendoPro 868-A“ management remote control, levels 1 to 5 can be selected and sent to the detector. With the „theSenda P“ installation remote control, the sensitivity can be reduced or increased by one level with every button press.

Level	Sensitivity
1	very insensitive
2	insensitive
3	Standard
4	sensitive
5	very sensitive

## Group address channel A

This parameter is applied when using the „theSenda P“ user remote control. A group address can be assigned to the channel A light.

The „SendoPro 868-A“ or „theSenda S“ can be used to program the group addresses in the detector.

## Group address value range

Adjustable values "SendoPro 868-A"	I, II, III, All
Adjustable values "theSenda S"	I, II

## LED display motion

The motion detection can be displayed via the LED.

## Value range

No display of motion detection.	Off
The LED switches on when motion is detected, otherwise switches off.	On

Adjustment possible only with „SendoPro 868-A“.

## Teach-in channel A

With teach-in, the currently measured brightness value is accepted as brightness switching value A. Values outside the permitted range will automatically be set to the appropriate limit value.

The control command teach-in can be adopted with the „SendoPro 868-A“ management remote control or with the „theSenda P“ installation remote control via the  button.

## Factory settings

The theRonda P360-101M presence detector is supplied with the following parameter values:

Parameter	Value
Brightness switching value A	300 lux
Time delay A	10 min
Short presence A	On
Time delay H	10 min
Switch-on delay H	0 s
Configuration type	auto
Control input S	auto
Detection sensitivity (PIR)	Stage 3
Group address	T
LED display movement	Off

## 9. Start-up

### Switching behaviour

Every time the power supply is switched on, the presence detector runs through two phases that are shown on an LED:

#### 1. Start-up phase (30 s)

- The red LED flashes every second, both switch contacts are closed (light and presence on).
- The detector does not react to push button commands and remote control commands.
- When no one is present both contacts open after 30 seconds.

## 2. Mode

The detector is ready for operation (LED off).

## Test presence

Presence test mode is used to test presence detection and wiring. Presence test mode can be activated with the „Sendo-Pro 868-A“ management remote control and with the „theSenda P“ installation remote control.

### Setting the presence test mode via remote control

- The detector goes directly into test mode when the test mode is set via the remote control:
- Every movement is indicated by the LED.
- When movement occurs the light and presence switch contacts close.
- When no one is present the light switch contact opens after 10 seconds.
- Brightness measurement deactivates, detector does not react to brightness.
- The detector reacts as in fully automatic function mode even if semi-automatic is set.
- Teach-in cannot be activated in test mode.
- Test mode ends automatically after 10 mins. The detector performs a new start (see switch-on behaviour).

## 10. Technical data

Operating voltage	110-230 V AC + 10 % / - 15%
Frequency	50-60 Hz
Upstream protection device	13 A
Power consumption	approx. 0.1 W
Type of installation	Ceiling installation; Flush / surface mounted or ceiling installation
Installation height	2,0 – 3,5 m / max. 15 m
Minimum height	> 1.7 m
Detection area horizontal	360°
Maximum range	Ø 8 m (Mh. 3 m) / 50 m <sup>2</sup> radially moving Ø 24 m (Mh. 3 m) / 452 m <sup>2</sup> tangentially moving
Setting range brightness switching value	30 – 3000 Lux
Lighting time delay	10 s – 60 min / Pulse
Presence time delay	10 s – 120 min
Switch-on delay "Presence"	0 s – 10 min
Channel A light	Relay 230 V / 10 A, µ-contact
Max. switching capacity cos φ = 1	2300 W
Max. switching capacity cos φ = 0.5	1150 VA
Max. switching capacity LED	see manufacturer concerning cos φ
LED lamps < 2 W	60 W
LED lamps > 2 W	600 W
Guidance value max. switch-on peak	800 A / 200 µs
Maximum number EBs T5/T8	16 x 54/58 W, 24 x 35/36 W 8 x 2 x 54/58 W 12x 2x 35/36 W
Channel H, presence	Floating relay, basic insulation
Maximum voltage	220 V DC / 250 V AC
Maximum switching capacity	50 W / 50 VA (max. 2 A)
Recommended minimum load	10 mV / 10 mA
Connection type	Terminals screws
Max. cable cross-section	max. 2 x 2.5 mm <sup>2</sup>
Flush-mounted socket size	Siz. 1, Ø 55 mm (NIS, PMI)
Protection rating	IP 54 (installed)

Ambient temperature	-15 °C ... 50 °C
CE Declaration of Conformity	This device conforms to the safety regulations of the EMC directive 2014/30/EU and of 2014/35/EU.

## Cleaning and service

- Only use a dry, soft cloth to clean the device surface.
- Do not use any cleaning agents or solvents.

## Disposal



Dispose of the device separately from domestic waste at an official collection point.

## Troubleshooting

Fault	Cause
Light does not switch on and/or off if presence is detected and in darkness	Lux value is set too low; detector set on semi-automatic; light was switched off manually via push button or „theSenda S“; person not within detection range; obstruction(s) interrupting detection; time delay set too short
Light stays on with detection of presence despite sufficient brightness	Lux value is set too high; light was briefly switched on manually via push button or with „theSenda S“ (wait 30 min.); detector is in test mode
Light does not switch off and/or light switches on spontaneously when no one is present	Wait for switch-off delay (self-learning); Thermal sources of interference in the detection area: fan heaters, incandescent lamps/halogen spotlights, moving objects (e.g. curtains hanging in an open windows); Load (EBs, relays) not cleared
Push button does not function	Device still in the start-up phase; illuminated push button was used without neutral conductor; Push button not led to the master
Light cannot be switched off with the push button	Push button not fed to the detector. Check wiring to the push button.
Device does not respond	Short circuit or several phases in parallel switching! Disconnect detector from the power supply for 5 mins. (thermal fuse)
Error flashing (4 x per second)	Error in self-test; Device not properly functional!

## LED display

LED	Description
Blinking in 1 second cycle	The presence detector is in the start-up phase.
Flickering for 2 s	The command sent from the remote control via infrared was accepted by the presence detector.
Lights up briefly	The command sent from the remote control via infrared was rejected by the presence detector. The command is not valid. Check the detector type or parameter selected in the SendoPro.
Fast blinking	Error blinking; The presence detector has found an error.
Flickering for 20 s	Teach-in via potentiometer is activated.
Lights or flickers irregularly	The presence detector is in presence test mode or "LED display movement" is activated. The LED displays detection of movement.

## Dimensional drawings

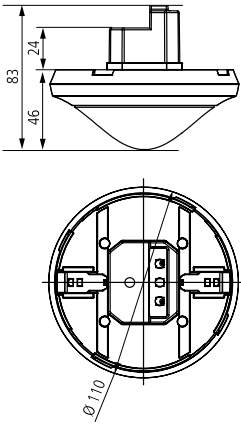

## 11. Accessories

Back box 110A WH

Item No.: 9070912

[Details > www.theben.de](http://www.theben.de)

Back box 110A GR

Item No.: 9070913

[Details > www.theben.de](http://www.theben.de)

SendoPro 868-A

Item No.: 9070675

[Details > www.theben.de](http://www.theben.de)

DE (ceiling installation) box 73A

Item No.: 9070917

[Details > www.theben.de](http://www.theben.de)

Covering clip for area restriction

Item No.: 9070921

[Details > www.theben.de](http://www.theben.de)

theSenda S

Item No.: 9070911

[Details > www.theben.de](http://www.theben.de)

theSenda P

Item No.: 9070910

[Details > www.theben.de](http://www.theben.de)

## 12. Contact

Theben AG

Hohenbergstr. 32

72401 Haigerloch

GERMANY

Phone +49 7474 692-0

Fax +49 7474 692-150

Technical Support

Phone +49 7474 692-369

[techsupport@theben.de](mailto:techsupport@theben.de)

[www.theben.de](http://www.theben.de)