

EN Presence detector

thePrema S360 KNX UP WH

2079500

thePrema S360 KNX UP GR

2079501



1. Product characteristics

- Passive infrared presence detector for ceiling mounting
- Square detection area 360° (up to 64 m²) for reliable and easy planning
- Automatic presence- and brightness-dependent control for lighting and HVAC
- Mixed light measurement suitable for fluorescent lamps (FL/PL/ESL), halogen/incandescent lamps and LEDs
- 2 light channels C1, C2
- Switching or constant light control with standby function (Orientation light)
- Switching operation with dimmable lighting
- Fully or semi-automatic
- Brightness switching value or set point value can be set in lux using parameters, on the device itself or via remote control
- Teaching in of the brightness switching value or the set point value
- Self-learning time delay can be set using parameters, object or via remote control

- Reduction of time delay when present briefly (short-term presence)
- Manual override by telegram or remote control
- 2 presence channels C4, C5, individually configurable
- Switch-on delay and time delay configurable
- Room monitoring with selective movement detection
- Setting the room correction factor for brightness measurement comparison
- Configurable sensitivity
- Exceptionally easy configuration of the energy-saving behaviour with the new „eco plus“ function
- Test mode for checking function and detection area
- Scenes
- Parallel switching of multiple presence detectors (Master/ Slave or Master/ Master)
- Ceiling installation in flush-mounted socket
- Ceiling installation possible with surface-mounted frame
- User remote control theSenda S (option)
- Management remote control SendaPro, installation remote control theSenda P (optional)

2. Safety



WARNING

Danger of death through electric shock or fire!

- Installation should only be carried out by a professional electrician!

- Work on electrical systems may only be carried out by electricians or by instructed persons under the leadership and supervision of an electrician in accordance with the technical regulations applying to electricity!
- Comply with the country-specific safety regulations for work on electrical systems! De-energise cable before installation!
- The device is maintenance-free. If the device is opened or penetrated with any objects the guarantee expires.

3. Intended use

The presence detector is intended for interior installation. The presence detector is exclusively intended for the use as contractually agreed between the manufacturer and the user. Any other use is considered to be unacceptable. The manufacturer does not accept liability for any resulting damages.

4. Function

The presence detector is primarily used in offices and schools, as well as in homes, for easy and energy-efficient control of lighting plus HVAC and shading. The lighting is appropriately influenced by switching or constant light control.

Function

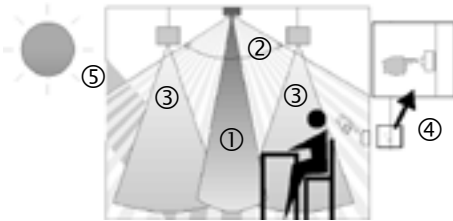

- ① Mixed light measurement
- ② Presence detection
- ③ Artificial light
- ④ Push button for manual lighting control
- ⑤ Incident daylight

Light channel C1, C2

The presence detector detects people present based on the smallest movements. Its light sensor simultaneously measures the brightness in the room and can thus smoothly control the lighting or switch it on and off according to the daylight. The light outputs can be dynamically faded up and down by the integrator. The brightness switching value or set point value can be done via parameters, object or the management remote control.

Switching

The lighting switches on with presence and insufficient brightness, and off with absence or sufficient brightness. Manual switching or dimming can be performed with a push button.

Constant light control

When constant light control is active, the brightness is held constant at the set point value. The control is started fully automatically or manually via push button or remote control. Manual switching off, dimming and scenes stop control for as long as the presence continues.

Time delay

The minimum time delay can be set for all light channels in the range of 30 seconds to 60 minutes. It adjusts automatically to the user's behaviour and can increase independently to 30 min or reduce back to the set minimum time. With settings ≤ 2 min or ≥ 30 min the time delay remains unchanged at the set value. If someone goes into an unoccupied room only briefly and leaves it within 30 seconds, then the light shuts off prematurely after 2 minutes (short-term presence).

Stand-by

The stand-by function acts as an orientation light. After the time delay expires, the lighting is set to the stand-by dimming value (1 - 25%). The stand-by time can be set between 30 s and 60 min or permanently. The lighting switches off if the brightness level in the rooms exceeds the brightness switching value / set point value. The lighting switches to the standby dimming value independently if the room brightness falls below the brightness switching value / set point value. The stand-by function can be activated or locked via an object. In conjunction with a time switch, this allows energy-saving solutions to be implemented.

Push button control

The lighting can be manually switched or dimmed at any time via a push button. If the light is switched on manually, the light will remain on during switching operation for at least

30 minutes provided people are present. It then switches off when there is enough brightness. The light is forced off after a preset time delay if the room was (previously) vacated. If artificial lighting is switched off manually, the lighting remains switched off as long as the room is occupied. The lighting switches again automatically after the time delay has expired.

Fully or semi-automatic

Lighting control via the presence detector operates fully automatically for increased comfort or semi-automatically for greater energy savings. In „fully automatic“ the lights switch on and off automatically. Light switching has to be completed manually in „semi-automatic mode“. The lighting is switched off automatically.

Exceptionally easy configuration of the energy-saving behaviour

By selecting “eco” for optimal switching behaviour or “eco plus” for maximum energy saving, users can adjust the presence detector to their requirements very easily.

Presence channel C4, C5

The presence channels are typically used for HVAC control. According to the selection, a telegram will only be sent due to presence, completely independently of the brightness and after expiry of the switch-on delay. After every telegram, the time delay will be restarted on every movement. Push buttons do not influence the presence channel.

Switch-on delay

The switch-on delay prevents instantaneous switch on. The telegram is sent only on expiry of the switch-on delay, provided that people are present at this time.

Time delay

The time delay enables delayed switching off of HVAC devices and systems after the room is vacated.

Room monitoring channel C6

In the room monitoring channel the sensitivity of the presence detection is reduced. A telegram is only sent when a significant movement occurs and indicates the presence of people with a high degree of certainty. A separate time delay is available for the room monitoring.

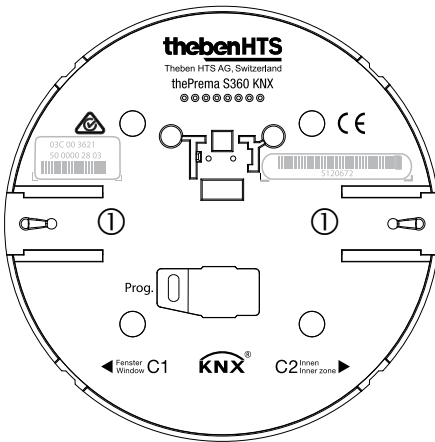

Mechanical safety lock ①

Note window / interior alignment.

5. Detection range

The square detection area of the presence detector guarantees accurate and simple planning. Square detection areas

make it possible to cover a whole room with parallel switching. Note that seated and moving persons can be detected in differently-sized areas. The recommended installation height is 2.0 m – 3.0 m. The sensitivity of the presence detector decreases with higher installation heights. Walking motions are necessary from installation heights of 3.0 m and the detection areas of several detectors should overlap in the marginal zones.

Seated persons:

The presence detector reacts very sensitively to the slightest movements. The details relate to the reduced detection area for movements at table height (approx. 0.80 m). The detection sensitivity is reduced from an installation height of > 3.0 m. More pronounced movements are required for clear detection.

Moving persons:

Use of the whole detection area.

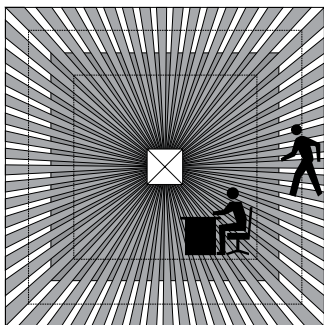
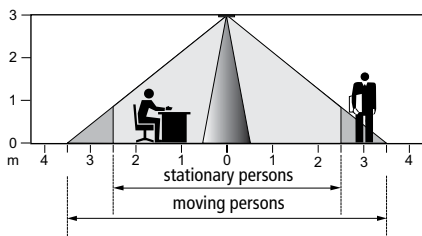

Installation height	stationary persons	moving persons
2,0 m	9 m ² 3,0m x 3,0m	20 m ² ± 0,5m 4,5m x 4,5m
2,5 m	16 m ² 4,0m x 4,0m	36 m ² ± 0,5m 6,0m x 6,0m
3,0 m	25 m ² 5,0m x 5,0m	49 m ² ± 1,0m 7,0m x 7,0m
3,5 m	-	64 m ² ± 1,0m 8,0m x 8,0m

Brightness measurement

The presence detector measures artificial and natural light (opening angle for each approx. $\pm 30^\circ$). The installation site is a reference point for the lighting level. The brightness measurement can be adapted to the conditions in a room with the room correction factor.

The use of the following light measurements is recommended: The light measurement area maps a rectangle of about 2 x 3.5 m at table height. During installation this rectangle can be adjusted with the help of the marking „window“ / „innen“ on the base plate..

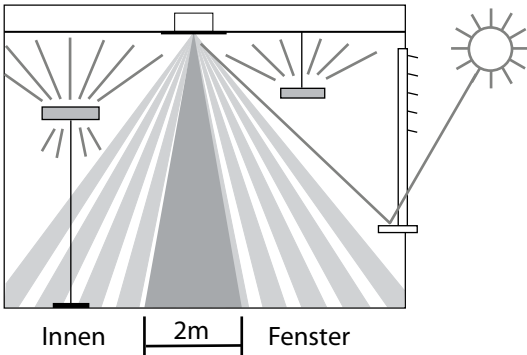

Switching

Direct light influences the light measurement. The placement of the floor lamps or suspended lighting directly below the detector is to be avoided.

Constant light control

The detector must be positioned in such a way that it only detects artificial light that it itself controls. Artificial light that is controlled by other detectors or manually switched work

lighting influence the brightness measurement of the detector. Direct artificial light on the detector must be avoided.

Suitable lamps

The presence detector is designed for the operation of fluorescent lamps, compact fluorescent lamps, halogen/incandescent lamps and LEDs.

6. Installation

Flush-mounted installation

The flush-mount installation of the presence detector is done using a standard UP (flush-mount) installation socket Size 1.

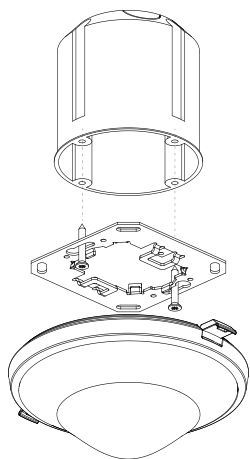

Ceiling installation

A ceiling installation unit is available for a simplified ceiling installation of the presence detector (see accessories). This ensures strain relief and contact protection at the same time. The installation diameter is 72 mm (drill diameter 73 mm).

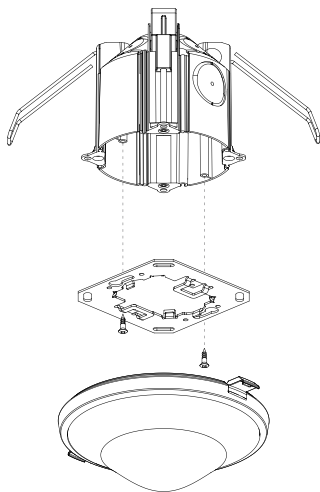

Surface-mount installation

A suitable surface-mount frame is available for surface mount installation (see accessories).

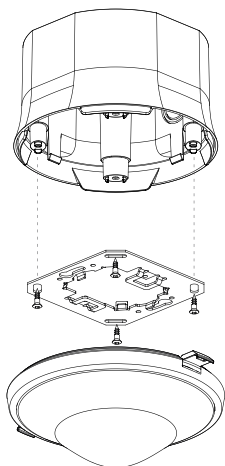

7. Start-up

1. Settings

All settings are made via ETS. See „KNX manual thePrema‘ document (application description).

The „SendoPro 868-A“ management remote control or the installation remote control „theSenda P“ are optionally available for installation support. The „SendoPro 868-A“ can be used to query, adjust and optimise parameters. Parameters can only be adjusted with the „theSenda P“. In this sense, the remote controls serve as set-up aids. A range of alterable parameters is available for adjustment with the remote control (see chapter „Parameters via remote control“).

The response during operation can be changed via the remote control's control commands.

2. Programming mode

The programming mode can be set using the program button on the back of the presence detector or via the „SendoPro 868-A“ management remote control or „theSenda P“ installation remote control without dismantling the presence detector.

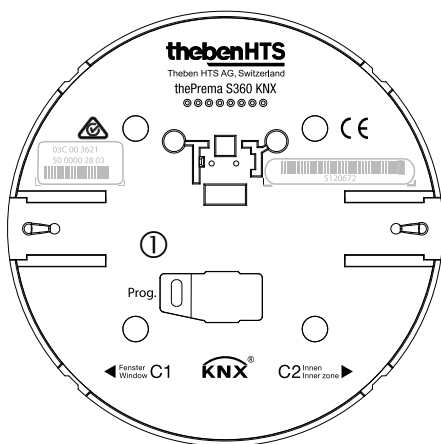

① Programming mode push button

3. Restore device factory settings

The presence detector is supplied with a factory setting. These factory settings can be restored.

Activation	Description
------------	-------------

Powerup	Hold down the program button while switching on bus voltage.
---------	--------------------------------------------------------------

4. Operation mode

The thePrema S360 KNX recognises 3 operating states

Normal

Presence test

Light test

5. Switch-on behaviour

After the bus voltage is switched on or the parameters are downloaded via the ETS, the detector runs through the start-up phase (shown by LED).

1. Start-up phase (30 s)

- The LED flashes once per second.
- Switching: Light outputs send an ON telegram regardless of brightness
- Constant light control: control inactive, the lighting will be dimmed up to the maximum (value telegram 100%).
- When no one is present or there is sufficient brightness after 30 s an OFF telegram is sent (light off).

2. Operation mode normal

- The detector is ready for operation (LED off).

3. Event of malfunction

- LED flashes rapidly
- For troubleshooting see "Troubleshooting" chapter

8. Parameters via remote control

The following parameters can be queried or changed via the remote control for support during installation as well as servicing:

Parameter	Description	Can be queried Sendo-Pro	Can be changed Sendo-Pro	Can be changed theSenda P
Brightness set point value C1	Value range in lux	x	x	x
Alternative brightness set point value C1	Value range in lux	x	x	
Brightness actual value C1	Measured brightness value in lux	x		
Brightness measurement value C1	Lux meter brightness value in lux		x	
Lighting time delay C1, C2	Value ranges in seconds and minutes		x	x
Detection sensitivity (PIR)	Value range in levels		x	x

With the "SendoPro 868-A" management remote control, parameters can be queried by sending values level-by-level to the detector, with the LED flickering briefly when there is a match.

This adjustment of parameters does not change the settings in ETS.

9. Alterable parameters via remote control

1. Adjustment with the remote control

The parameters are sent to the presence detector with the management remote control "SendoPro 868-A" or installation remote control "theSenda P" via infra-red. Changed parameters are immediately applied and used by the detector.

LED description

Flickering for 2 s

After activating the send function on the management remote control or pressing the corresponding push button on the theSenda P, the presence detector indicates correct reception by flickering for 2 s.

Lights up briefly

The parameter/command sent from the remote control was rejected by the presence detector. The command is not valid. Check selected detector type and sent parameters with management remote control.

2. Brightness switching value / Set point value channel C1 light

The brightness switching value / set point value defines the minimum desired brightness. The current prevailing brightness is measured below the presence detector. If the prevailing brightness is below the switching value / set point value, the light switches on when a presence is detected (in fully automatic operation).

Value range

- Lux values with "SendoPro 868-A" management remote control: 5 - 3000 Lux
- In the installation remote control "theSenda P", the following values are available: 5, 10, 15, 300, 500, 800 lux
- (The currently measured brightness value (Lux) can be applied with the management remote control "SendoPro 868-A", with the Teach-in control command or with the installation remote control "theSenda P" with the Teach-in button.)
- Values outside the permitted range will automatically be set to the appropriate limit value.
- Deactivation of the brightness measurement during switching operation (the brightness has no influence): Measurement off
- The light channels only switch after presence/absence

3. Alternative brightness switching value / set point value channel C1 light

The alternative brightness switching value / set point value can be used to define a second different brightness switching / set point value. For example, a day and night mode with two different brightness levels can be set up in combination with the brightness switching value / set point value channel C1 light. The alternative brightness switching value / set point value is activated or switched via bus object.

Value range

- Lux values with "SendoPro 868-A" management remote control: 5 - 3000 Lux
- In the installation remote control "theSenda P", the following values are available: 5, 10, 15, 300, 500, 800 lux

- (The currently measured brightness value (Lux) can be applied with the management remote control "SendoPro 868-A", with the Teach-in control command or with the installation remote control "theSenda P" with the Teach-in button.)
- Values outside the permitted range will automatically be set to the appropriate limit value.
- Deactivation of the brightness measurement during switching operation (the brightness has no influence): Measurement off
- The light channels only switch after presence/absence

4. Room correction factor C1

The room correction factor is a measurement for the difference between brightness measurements on the ceiling and the work area.

The brightness measurement value on the ceiling is influenced by the installation point, light reception, position of the sun, weather conditions, the reflection properties of the room and furniture.

The brightness measurement value of the corresponding light channel is adjusted to the conditions in the room using the room correction factor and can therefore be compared to the lux meter value ① measured in the area below the presence detector.

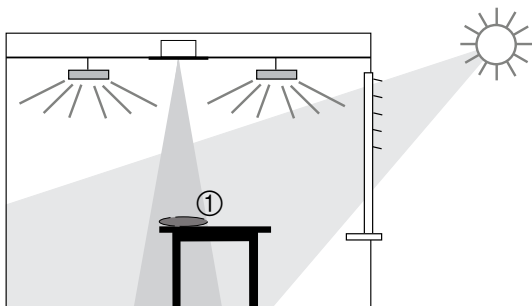

Room correction factor = $\frac{\text{Brightness value on the ceiling}}{\text{Brightness value on the work surface}}$

- Please note the instructions in the “KNX thePrema” manual concerning the calibration of light measurements or setting the room correction factor.
- The Lux meter is placed on the work surface below the sensor and the measured lux value is entered via the management remote control “SendoPro 868-A”.
- The room correction factor is calculated from this automatically. Values between 0.05 and 2.0 are permitted. Calculated or entered values outside the permitted range will be automatically set to the appropriate limit value.



The room correction factor can be changed directly only via the ETS.
The standard value is 0.3 and is suitable for most applications.
Changes are only sensible in sharply varying situations.

5. Detection sensitivity

The detector has 5 sensitivity levels. The basic setting is the middle level (3). The sensitivity also applies during

the test mode. By selecting the presence test operation mode, the set sensitivity level is not changed. With the management remote control „SendoPro 868-A“, levels 1 to 5 can be selected and sent to the detector. With the installation remote control, „theSenda P“ the sensitivity can be reduced or increased by one level with every button press.

Level	Sensitivity
1	very insensitive
2	insensitive
3	standard
4	sensitive
5	very sensitive

Test mode

The thePrema S360 KNX has two test modes.

- Presence test
- Light test

1. Presence test

The presence test is used to check the presence detection and parallel switching.

Activation	Presence test "on" with the management remote control "SendoPro 868-A" or installation remote control "theSenda P" push button "Presence test" A telegram via bus object (51) The presence test mode can be activated at anytime.
------------	-----------------------------------------------------------------------------------------------------------------------------------------------------------------------------------------------------------------------------------------

End	With subsequent restart: Test presence "Off" command with the "SendoPro 868-A" management remote control Off telegram via bus object (51) Power failure and power up Automatically according to the time set in the ETS Without restart: Activation of test light with the "SendoPro 868-A" management remote control
-----	-----------------------------------------------------------------------------------------------------------------------------------------------------------------------------------------------------------------------------------------------------------------------------------------------------------------------------------------

LED display Status channels	Description
On	When movement occurs, the LED goes on and channels C1, C2 close.
Off	After the movement stops, the LED is off and the channels C1, C2 open after approx. 10 s.

Test response

- Deactivate brightness measurement, light output does not react to brightness
- The detector reacts as in fully automatic function mode even if semi-automatic is set.
- The control type changes to switching if the control type is set to constant light control. The light is not controlled.
- Light "On" during movement; light "Off" during absence
- Channels C1 and C2 have a fixed time delay of 10 s.
- The presence and room monitoring channels react unchanged as in normal operating mode.

Commands and other parameters

The following commands are possible with the "SendoPro 868-A" management remote control in the presence test mode:

- End test presence

- Activate test light
- Change detection sensitivity

The selected detection sensitivity (1 .. 5) is unchanged on activation of the presence test. Sensitivity can be adjusted during the test.

The presence detector performs a restart after the end of the test mode.

2. Light test

The light test is used to check the brightness switching value / set point value.

Activa- tion	Control command Test presence "On" with the "SendoPro 868-A" management remote control A telegram via bus object (52) The light test mode can always be activated at anytime
-----------------	------------------------------------------------------------------------------------------------------------------------------------------------------------------------------------

End	With subsequent restart: Light test "Off" Control command with the management remote control "SendoPro 868-A" Off telegram via bus object (52) Power failure and power up Automatically according to the time set with the ETS Without restart: Activation of test presence with „SendoPro 868-A“ management remote control
-----	-----------------------------------------------------------------------------------------------------------------------------------------------------------------------------------------------------------------------------------------------------------------------------------------------------------------------------------------------

LED display	Description
Flashing, 5 s On 0.3 s Off	The LED flashes as long as the test light is active.

Test response

The presence detector responds 100% like in normal operation, only the reaction to bright/dark is faster. This makes it possible to test the brightness threshold and the adaptive response. The control is also faster. All selected functions and parameters remain unchanged.

Commands and other parameters

The following commands are possible with the "SendoPro 868-A" management remote control in the light test mode:

- End test light
- Change brightness switching value / set point value channel C1 light
- Activate test presence

The presence detector performs a reset after the end of the test mode.



Do not use a table lamp to switch the presence detector. The presence detector will learn this and thereby distort the adaptive light thresholds and hysteresis values. In order to simulate this behaviour, the area below the presence detector should be illuminated or the blinds operated. Reactivate the test light for a new test.

Control commands

The following control commands can be triggered with the remote control:

Control command	Description	Can be queried SendoPro	Can be triggered SendoPro	Can be triggered theSenda P
Restart	Restart detector		x	x
Teach-in channel C1	The current measured brightness value will be accepted as the brightness set point value. Transfer is made to current active brightness level. That is, if the alternative brightness set point value is switched to, the current measured brightness value [lux] is transferred to the alternative brightness set point value via the teach-in command. The value transfer is not carried out if the measured brightness value is outside the value range of the brightness set point value (displayed via LED). Values outside the permitted range will automatically be set to the appropriate limit value..		x	x
Teach-in channel C1 + C2				x
Presence test	On / Off		x	x
Test light	On / Off		x	
All light groups	All light groups can be switched on and off.		x	x
Master/Slave query	Master / Slave		x	
Programming mode	Activation of programming mode		x	x

Troubleshooting

Fault	Cause
Light does not switch on and/or switches off if presence is detected and in darkness	Lux value is set too low; detector set on semi-automatic; light was switched off manually via push button or with remote control; person not within detection range; obstruction(s) interrupting detection; time delay set too short.
Light stays on when someone is present despite sufficient brightness	Lux value is set too high; light was recently switched on manually via push button or by remote control (wait 30 min during switching operation); detector is in testing mode.
Light does not switch off and/or light switches on spontaneously when no one is present	Wait for time delay (self-learning); thermal sources of interference in the detection area: fan heaters, incandescent lamps / halogen spotlights, moving objects (e.g. curtains hanging in an open window).
Error flashing (3 x per second)	Error in self-test; Device not properly functional!

LED display

LED	Description
Blinking in 1 second cycle	The presence detector is in the start-up phase.
Flickering for 2 s	The command sent from the remote control via infrared was accepted by the presence detector.
Lights up briefly	The command sent from the remote control via infrared was rejected by the presence detector. The command is not valid. Check the detector type or parameter selected in the SendoPro.
Fast blinking	Error blinking; The presence detector has found an error.
Flashing, 5 s On 0.3 s Off	The presence detector is in light test mode.
Lights or flickers irregularly	The presence detector is in presence test mode or "LED display movement" is activated. The LED displays detection of movement.

Dimensional drawings

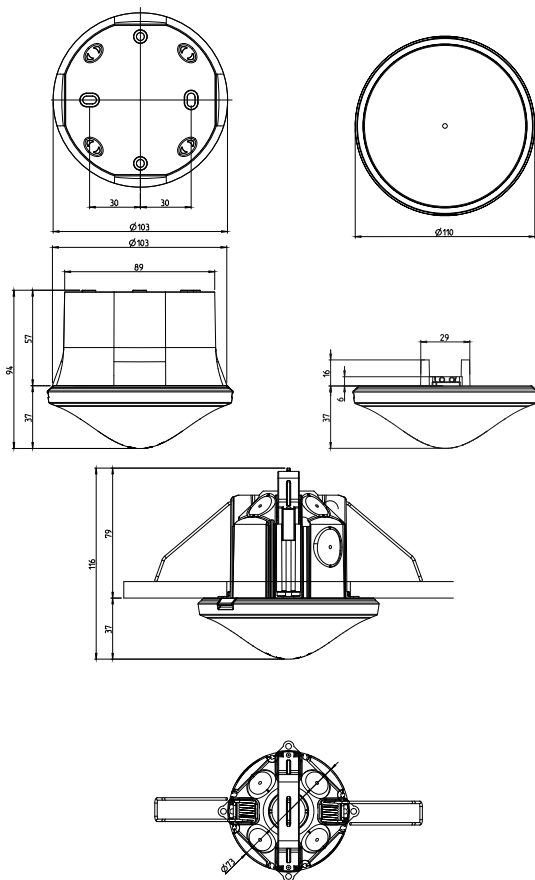

Accessories

Surface-mount frame 110A

Item No.: 9070912

[Details > www.theben.de](http://www.theben.de)

SendoPro 868-A

Item No.: 9070675

[Details > www.theben.de](http://www.theben.de)

Ceiling installation set

Item no.: 9070917

[Details > www.theben.de](http://www.theben.de)

theSenda S

Item No.: 9070911

[Details > www.theben.de](http://www.theben.de)

theSenda P

Item No.: 9070910

[Details > www.theben.de](http://www.theben.de)

Product overview

Installation type	Channel	Colour	Type	Item No.
Ceiling installation	2 Light 2 HVAC	White	thePrema S360 KNX UP WH	2079500
Ceiling installation	2 Light 2 HVAC	Grey	thePrema S360 KNX UP GR	2079501
Ceiling installation	2 Light 2 HVAC	Special colour in accordance with customer information	thePrema S360 KNX UP SF	2079503

Guarantee

ThebenHTS presence detectors are manufactured with the utmost care and using state-of-the-art technology and are quality-tested. ThebenHTS AG therefore guarantees perfect operation when used correctly. Should a fault occur, however, ThebenHTS AG will fulfil the guarantee within the scope of the general terms and conditions.

Please note in particular:

- that the guarantee is invalidated if you, or a third party, make changes or undertake repairs to the devices.
- that, insofar as the presence detectors are connected to a software-controlled system, the guarantee for this connection is only valid when the indicated interface specification is complied with.

We undertake to repair or place as quickly as possible all components of the delivered device that have become defective or unusable through demonstrably poor material,

faulty construction or incomplete delivery up to the end of the guarantee period.

Returns

In the event of a guarantee claim, please return the device to the relevant dealer together with the delivery note and a brief description of the fault.

Industrial property rights

The design as well as hardware and software of these devices are protected by copyright.

10. Technical data

Operating voltage	Bus voltage KNX, max. 30 V
Power consumption	approx. 9 mA / 13 mA with LED on
Installation type	Ceiling installation; Flush/surface mounted or ceiling installation
Recommended installation height	2.0 – 3.0 m (minimum height > 1.7 m)
Detection area horizontal Vertical	360° 120°
Maximum range	5 x 5 m (Mh. 3 m) / 25 m ² seated 8 x 8 m (Mh. 3,5 m) / 64 m ² moving
Setting range brightness switching value / set point value	approx. 5 – 3000 Lux
Lighting time delay	30 s – 60 min
Presence time delay	10 s – 120 min
Presence switch-on delay	10 s – 30 min / inactive

Standby dimming value	1 – 25% of the lamp output
Stand-by time	30 s – 60 min / inactive / permanently on
All settings are remotely configurable	see KNX handbook
Connection type	WAGO 243 screwless terminals
Flush-mounted socket size	Siz. 1, Ø 55 mm (NIS, PMI)
Protection rating	IP 20 (installed IP 40)
Ambient temperature	0 °C – 50 °C
CE Declaration of Conformity	This device conforms to the safety regulations of the EMC directive 2004/108/EC
RCM compliance	This device is compliant with the ACMA guidelines

ThebenHTS AG

Im Langhag 7b

8307 Effretikon

SCHWEIZ

Tel. +41 52 355 17 00

Fax +41 52 355 17 01

Hotline

Tel. +41 52 355 17 27

hotline@theben-hts.ch

Addresses, telephone numbers etc.

www.theben-hts.ch