



- User remote control «theSenda S» (optional)
- Management remote control «SendoPro» (optional)
- Installation remote control «theSenda P» (optional)

## 2. Basic safety information



Make yourself familiar with the presence detector, prior to installation and start-up. Read these operating instructions and the «KNX-PlanoSpot manual».

- Work on electrical systems may only be carried out by qualified electricians or by instructed persons under the guidance and supervision of a qualified electrician in accordance with the technical regulations applying to electricity!
- Comply with the country-specific safety regulations for work on electrical systems! Ensure absence of voltage in the cable before installation!
- The device is maintenance-free. If the device is opened or penetrated with any object, the guarantee lapses.

## 1. Product characteristics

- Passive infrared presence detectors for ceiling installation
- Flat design with interchangeable cover frame in different colors
- Square detection area 360° (up to 64 m<sup>2</sup>) for reliable and easy planning
- Automatic presence- and brightness-dependent control for lighting and HVAC
- Two differently sized detection zones for greater flexibility. Adjustable via parameters or remote control.
- Mixed light measurement suitable for fluorescent lamps (FL/PL/ESL), halogen/incandescent lamps and LEDs
- 3 directed light measurements
- 2 light channels C1, C2 with 2 light measurements and additional lighting channel C3 without brightness factor
- Switched or constant light control with 2 independent control systems and standby function (orientation light)
- Switching mode with dimmable lighting
- Fully or semi-automatic
- Brightness switching value or set point value can be set in lux by using parameters, the object or via remote control
- Teach-in of the brightness switching value or the set point value
- Light time delay configurable
- Self-learning time delay can be set using parameters, object or via remote control
- Reduction of time delay when present briefly (short-term presence)
- Manual override by telegram or remote control
- 2 presence channels C4, C5, individually configurable
- Switch-on delay and time delay configurable
- Room monitoring with selective movement detection
- Setting the room correction factor for brightness measurement comparison
- Configurable sensitivity
- Extremely simple setting of the energy-saving ratio with the new «eco plus» function
- Test mode for checking function and detection area
- Scenarios
- Parallel switching of multiple presence detectors (Master/Slave or Master/Master)
- Installation in false ceilings with springs
- Surface mounting on ceilings possible with the AP-frame (optional)

## 3. Proper use

The presence detector is intended for interior installation. The presence detector is exclusively intended for the use as contractually agreed between the manufacturer and the user. Any other use is considered to be unacceptable. The manufacturer does not accept liability for any resulting damages.

## 4. Operation

The presence detector is primarily used in offices and schools, as well as in homes, for easy and energy-efficient control of lighting plus HVAC and shading. The lighting is accordingly influenced by switching or constant light control.

### Operation

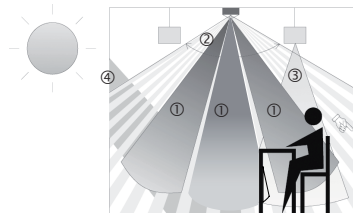

- ① Mixed light measurement
- ② Presence detection
- ③ Artificial light
- ④ Incident daylight

### Light channel C1, C2, C3

The presence detector detects people present based on smallest movements. Its 3 light sensors simultaneously measure the brightness in the room and can thus steplessly control the lighting or switch it on and off according to the daylight. The light outputs can be dynamically faded up and down by the integrator. The brightness switching value or set point value

is adjusted by means of a parameter, object or the remote control.

### Switching

The lighting switches on with presence and insufficient brightness, and off with absence or sufficient brightness. Manual switching or dimming can be performed with a push button. Manual switching off, dimming and scenes stop the control for the duration of the presence.

### Constant light control

When constant light control is active, the brightness is held constant at the brightness set point value. Control is started fully automatically or manually via push button or remote control. Manual switching off, dimming and scenes stop control for as long as the presence continues.

### Time delay

The minimum time delay can be set for all light channels in the range of 30 seconds to 60 minutes. It adjusts automatically to the user's behaviour and can increase independently to 30 min or reduce back to the set minimum time. With settings  $\leq 2$  min or  $\geq 30$  min the time delay remains unchanged at the set value. If someone goes into an unoccupied room only briefly and leaves it within 30 seconds, then the light will be switched off prematurely after 2 minutes (short-term presence).

### Standby

The standby function acts as an orientation light. After the time delay expires, the lighting is set to the standby dimming value (1 - 25 %). The standby time can be set between 30 s and 60 min or permanently. The lighting switches off if the brightness level in the rooms exceeds the brightness switching value / set point value. The lighting switches to the standby dimming value independently if the room brightness falls below the brightness switching value / set point value. The standby function can be activated or locked via an object. In conjunction with a time switch, this allows energy-saving solutions to be implemented.

### Push button control

The lighting can be manually switched or dimmed at any time via a push button. If the light is switched on manually, the light will remain on during switching operation for at least 30 minutes provided people are present. It then switches off when there is enough brightness. The light is forced off after a preset time delay if the room was (previously) vacated. If artificial lighting is switched off manually, the lighting remains switched off as long as the room is occupied. The lighting switches again automatically after the time delay has expired.

### Fully or semi-automatic

Lighting control via the presence detector operates fully automatically for increased comfort or semi-automatically for greater energy savings. In "fully automatic device" the lighting is switched on and off automatically. In "semi-automatic", the lighting must always be switched on manually. The lighting is switched off automatically.

### Exceptionally easy configuration of the energy-saving behaviour

By using the selection «eco» for optimal switching behaviour or «eco plus» for maximum energy savings, users can adjust

the presence detector to their needs in an extremely easy manner.

## Presence channel C4, C5

The presence channels are typically used for HVAC control. According to the selection, a telegram will only be sent in case of presence, completely independently of the brightness and after expiry of the switch-on delay. After every telegram, the time delay is started again with every motion. Buttons do not affect the presence channel.

### Switch-on delay

The switch-on delay prevents instantaneous switching on. The telegram is sent only on expiry of the switch-on delay, provided that people are present at this time.

### Time delay

The time delay enables delayed switching off of HVAC devices and systems after the room is vacated. If selected, a telegram can be sent after the expiry of the presence time delay (once or cyclical).

### Room monitoring channel C6

In the room monitoring channel the sensitivity of the presence detection is reduced. A telegram is only sent when a significant movement occurs and indicates the presence of people with a high degree of certainty. A separate time delay is available for the room monitoring.

## 5. Detection area

The square detection area of the presence detector guarantees accurate and simple planning. Two detection zones are available; the user can switch between them by means of a parameter or the management remote control. Note that seated and moving persons can be detected in differently-sized areas.

The recommended installation height is 2 m – 3 m. As installation height increases, the sensitivity of the presence detector decreases. At an installation height of 3 m or higher, walking motions are necessary and the detection areas of several detectors should overlap around the perimeter. The detection range is reduced as the temperature increases. This sensitivity can be adjusted in 5 levels via a parameter or the remote control.

### Seated persons:

The presence detector reacts very sensitively to the slightest movements. The information refers to movements at table height (approx. 0.08 m).

### Moving persons:

With an installation height of  $> 3$  m, the size and distance between the active and passive zones increase. More pronounced movements are required for clear detection.

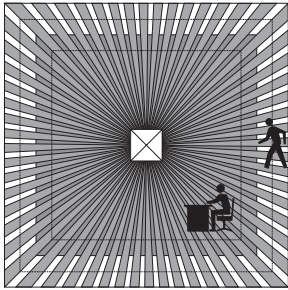
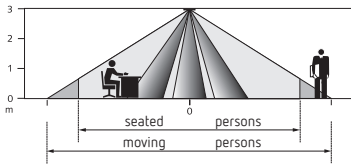

### Standard detection zone

Installation height	stationary persons		moving persons	
2.0 m	9 m <sup>2</sup>	3.0 m x 3.0 m	20 m <sup>2</sup>	4.5 m x 4.5 m ± 0.5 m
2.5 m	16 m <sup>2</sup>	4.0 m x 4.0 m	36 m <sup>2</sup>	6.0 m x 6.0 m ± 0.5 m
3.0 m	20 m <sup>2</sup>	4.5 m x 4.5 m	49 m <sup>2</sup>	7.0 m x 7.0 m ± 1.0 m
3.5 m	-	-	64 m <sup>2</sup>	8.0 m x 8.0 m ± 1.0 m

### Reduced detection zone

Installation height	stationary persons		moving persons	
2.0 m	4.0 m <sup>2</sup>	2.0 m x 2.0 m	4.4 m <sup>2</sup>	2.1 m x 2.1 m ± 0.5 m
2.5 m	6.3 m <sup>2</sup>	2.5 m x 2.5 m	9.0 m <sup>2</sup>	3.0 m x 3.0 m ± 0.5 m
3.0 m	9.0 m <sup>2</sup>	3.0 m x 3.0 m	14.4 m <sup>2</sup>	3.8 m x 3.8 m ± 1.0 m
3.5 m	-	-	22.1 m <sup>2</sup>	4.7 m x 4.7 m ± 1.0 m

### Brightness measurement

The presence detector measures artificial light and daylight by means of three directed light measurements. The central light measurement detects the brightness directly below the detector (A), while the two other light measurements detect the brightness close to the window (B) or in the interior (C). The installation location is the reference point for the lighting level. The brightness measurement can be adapted to the conditions in a room with the room correction factor.

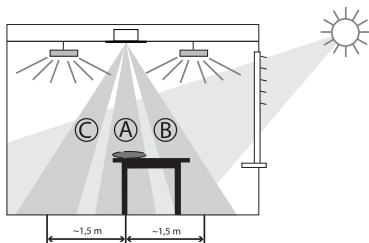

The use of the following light measurements is recommended:

- Switching or constant light control 1-channel: Use of the centre light measurement.
- Switching or constant light regulation 2-channel: only the two light measurements, window or interior, are available.

### Switching

Direct light influences the light measurement. The placement of floor lamps or suspended lighting directly below the detector is to be avoided.

### Constant light control

The detector must be positioned in such a way that it only detects artificial light that it controls itself. Artificial light that is controlled by other detectors, or manually switched work lighting, influence the brightness measurement of the detector. Direct artificial light on the detector must be avoided.

### Suitable lamps

The presence detector is designed for the operation of fluorescent, compact fluorescent, halogen and incandescent lamps as well as LEDs.

## 6. Installation

### Ceiling installation

Installation in false ceilings for ceiling thicknesses of 0.5 mm to 3 cm. The drill diameter for the ceiling cut-out is 68 mm. Attach KNX cable (a). Open springs and mount detector in ceiling (b). Pay attention to window / interior alignment (c). Remove installation protection (d). Snap on the cover frame provided (e).

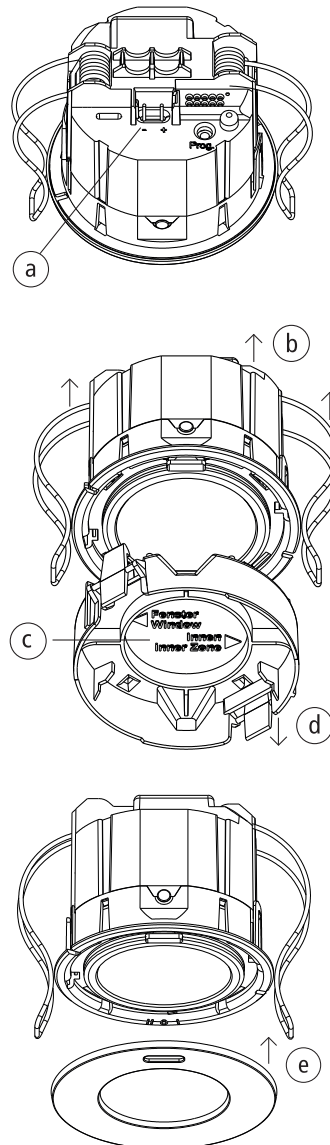

## Surface-mounted installation

Pull out both springs from the detector (g) and replace with the springs provided with the AP-frame 75A (h). Install the AP-frame 75A on the ceiling (i). Attach KNX cable (a) and push the detector into the AP-frame (j). Pay attention to window / interior alignment (c). Remove installation protection (d). Snap on the cover frame provided (e).

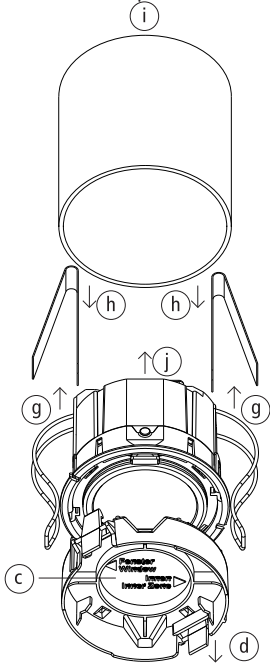

## 7. Start-up

### 1. Settings

All settings are made via ETS. Refer to the document «KNX-PlanoSpot manual» (application description). For assistance with commissioning, the optional «SendoPro 868-A» management remote control or the «theSenda P» installation remote control is available. Parameters can be queried, adjusted and optimised with the «SendoPro 868-A». Parameters can only be adjusted with the «theSenda P». In this sense, the remote controls serve as set-up aids. A range of variable parameters is available for adjustment via the remote control (see chapter «Parameters via remote control»).

The response during operation can be changed via the remote control's control commands.

### 2. Programming mode

The programming mode can be activated either by means of the programming button on the back of the presence detector or, without removing the presence detector, by means of the «SendoPro 868-A» management remote control or «theSenda P» installation remote control.

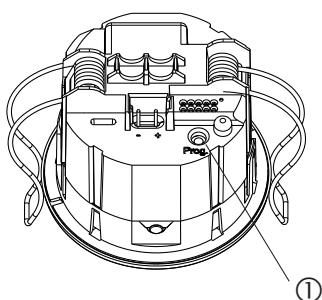

① Programming mode push button

## 3. Restore device factory settings

The presence detector is supplied with a factory setting. This factory setting can be restored.

Activation	Description
Power up	Hold down the programming button while switching on the bus voltage.

## 4. Operation mode

The PlanoSpot 360 KNX S has 3 operation modes

Normal      Presence test      Light test

## 5. Switch-on behaviour

After the bus voltage is switched on or the parameters are downloaded via the ETS, the detector first runs through the start-up phase of 30 s, then it changes into normal operation. An LED displays the current status.

### 1. Start-up phase (30 s)

- The LED flashes at one second intervals.
- Switching: Light outputs send an ON telegram regardless of brightness.
- Constant light control: Control inactive; the lighting will be dimmed up to the maximum (value telegram 100 %).
- When no one is present or there is sufficient brightness, an OFF telegram is sent after 30 s (light off).

### 2. Operation mode normal

- The detector is ready for operation (LED off).

### 3. Event of malfunction

- LED flashes rapidly
- For troubleshooting, see the chapter «Troubleshooting»

## 8. Parameters via remote control

The following parameters can be queried or changed via the remote control for support during installation as well as servicing:

Parameter	Description	Can be queried SendoPro	Can be changed Sendo-Pro	Can be changed theSenda P
Brightness set point value C1	Value range in lux	x	x	x
Alternative brightness set point value C1	Value range in lux	x	x	
Brightness measurement value C1	Luxmeter brightness value in lux		x	
Brightness actual value C1	Measured brightness value in lux	x		
Brightness set point value C2	Value range in lux	x	x	x
Alternative brightness set point value C2	Value range in lux	x	x	
Brightness measurement value C2	Luxmeter brightness value in lux		x	
Brightness actual value C2	Measured brightness value in lux	x		
Lighting time delay	Value ranges in seconds / minutes		x	x
Detection zone	Selection of detection area		x	
Detection sensitivity (PIR)	Value range in increments		x	x

With the "SendoPro 868-A" management remote control, parameters can be queried by sending values level-by-level to the detector. If the sent values are below the set parameter, the LED illuminates briefly. If the sent values are equal or above the set parameter, the LED flickers for 2 seconds. This adjustment of parameters does not change the settings in ETS.

## 9. Alterable parameters via remote control

### 1. Adjustment with the remote control

The parameters are sent to the presence detector with the "SendoPro 868-A" management remote control or with "theSenda P" installation remote control via infra-red. Changed parameters are immediately applied and used by the detector.

#### LED description

#### Flickering for 2 s

After activating the send function on the management remote control or pressing the corresponding push button on the theSenda P, the presence detector indicates correct reception by flickering for 2 s.

#### Lighting up briefly



The parameter/command sent from the remote control was rejected by the presence detector. The command is not valid. Check selected detector type and sent parameters with management remote control.

### 2. Brightness switching value / Set point value channel C1, C2 light

The brightness switching value/set point value defines the minimum desired brightness. The currently prevailing

brightness is measured below the presence detector. If the prevailing brightness is below the switching value/set point value, the light is switched on when a presence is detected (in configuration type fully automatic).

#### Value range

- Lux values with "SendoPro 868-A" management remote control: 10-3000 lux
- The following values are available with the «theSenda P» installation remote control: 10, 15, 300, 500, 800 lux
- The currently measured brightness value (lux) can be adopted with the "SendoPro 868-A" management remote control by using the teach-in control command, or with the "theSenda P" installation remote control via the teach-in  button. Values outside the permitted range will automatically be set to the appropriate limit value.
- Deactivation of the brightness measurement (the brightness has no effect). The light channels switch only on the basis of presence/absence. Possible with the «SendoPro 868-A» management remote control (measuring off) or the «theSenda P» installation remote control (button .

### 3. Alternative brightness switching value / set point value channel C1, C2 light

The alternative brightness switching value / set point value can be used to define a second different brightness switching / set point value. For example, a day and night mode with two different brightness levels can be set up in combination with the brightness switching value / set point value channel C1 and C2 light. The alternative brightness switching value / set point value is activated or switched via bus object.

#### Value range

cf. 2nd brightness switching value / set point value channel C1, C2 light

### 4. Room correction factor C1, C2

The room correction factor is a measurement for the difference between brightness measurements on the ceiling and the work area. The brightness measurement value at the ceiling is influenced by the installation location, incidence of light, position of the sun, weather conditions, the reflection properties of the room and the furniture.

With the room correction factor, the measured brightness value of the corresponding light channel is adjusted to the conditions in the room and in this way can be matched to the luxmeter value ① measured at the surface beneath the presence detector.

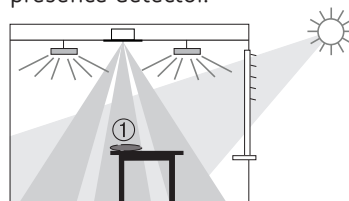

Room correction factor = Brightness value at the ceiling / brightness value at the working surface

- Please refer to the «KNX-PlanoSpot manual» for calibrating the light measurements and setting the room correction factor.

- The luxmeter is placed on the working surface beneath the sensor and the measured lux value entered via the «SendoPro 868-A» management remote control as parameter <Measured brightness value C1/C2>.
- The room correction factor is calculated from this automatically. Values between 0.05 and 2.0 are permitted. Calculated or entered values outside the permitted range will automatically be set to the appropriate limit value.

The calculated room correction factor will be applied immediately. As a check, the room correction factor can be queried via object 8 for channel C1 and via object 19 for channel C2.

	The room correction factor can be changed directly only via the ETS. The standard value is 0.3 and is suitable for most applications. Changes are only sensible in sharply varying situations.
--	---

## 5. Light time delay

### Value range

Adjustable values with "SendoPro 868-A" management remote control	30 s - 60 min.
In the "theSenda P" installation remote control, the following values are available	30 s, 60 s, 2 min., 10 min., 20 min., 60 min.

## 6. Detection zone

The detector has two differently sized detection zones. These can be selected easily with the management remote control via the «Detection zone» parameter. Available selections: «Standard» (max. detection area moving 8 x 8 m) or «Reduced» (max. detection area moving 4.7 x 4.7 m). Also see chapter 5. Detection area.

Alternatively, the detection zones can be selected in the ETS via the «Detection zone» parameter. See «KNX-PlanoSpot manual» document.

## 7. Detection sensitivity

The detector has 5 sensitivity increments. The basic setting is the middle increment (3). Sensitivity also applies during test mode. By selecting the test presence operation mode, the set sensitivity increment is not changed. Level 1 to 5 can be selected and sent to the detector with the «SendoPro 868-A» management remote control. On the «theSenda P» installation remote control, the sensitivity can be increased or decreased by one level each time the button is pushed.

Increment	Sensitivity
1	very insensitive
2	insensitive
3	Standard
4	sensitive
5	very sensitive

## 10. Control commands via remote control

The following control commands can be triggered with the remote control:

Control command	Description	Can be queried SendoPro	Can be triggered SendoPro	Can be triggered theSenda P
Programming mode	Activation of programming mode		x	x
Teach-in channel C1			x	x
Teach-in channel C2			x	x
Teach-in channel C1 + C2			x	x
Master/Slave query	Master / Slave		x	
Switching light	All lighting groups can be switched on and off.		x	x
Presence test	On/Off		x	x
Light test	On/Off		x	
Restart	Restart detector		x	x

### Teach-in

The currently measured brightness value will be accepted as the brightness set point value. Transfer is made to the currently active brightness set point value. This means that when switched to the alternative brightness set point value, the currently measured brightness value (lux) is transferred to the alternative brightness set point value by the teach-in command. Values outside the permitted range will automatically be set to the appropriate limit value.

### Test mode

The PlanoSpot 360 KNX S has two test modes.

- Presence test
- Light test

#### 1. Presence test

The presence test is used for checking the detection area and the parallel switching.

Activation	Control command test presence «On» with the «SendoPro 868-A» management remote control or «theSenda P» installation remote control, button «Test». ☒ ON telegram via bus object (51). The presence test can be activated anytime.
End	With subsequent restart: Control command test presence «Off» with the «SendoPro 868-A» management remote control or with «theSenda P» installation remote control, button ⏪ (Reset). OFF telegram via bus object (51) Mains failure and thus power up Automatically according to the time set with the ETS, without restart: Activation of light test with the "SendoPro 868-A" management remote control.

Indication of LED status channels	Description
On	In the event of movement, the LED is on and the channels C1, C2 switch on.
Off	After the movement stops, the LED is off and the channels C1, C2 switch after approx. 10 s.

### Test response

- Deactivated brightness measurement, light output does not react to brightness

- The detector reacts as in configuration type fully automatic device, even if semi-automatic device is set.
- The control type changes to switching if the control type is set to constant light control. The light is not controlled.
- Light "On" during motion; light "Off" during absence
- Lighting channels C1 and C2 have a fixed time delay of 10 s.
- The presence and room monitoring channels react unchanged as in normal operation.

### Commands and adjustable parameters

In the presence test mode, the following commands are possible with the «SendoPro 868-A» management remote control:

- End presence test
- Activate the light test
- Change the detection zone
- Change the detection sensitivity

The selected detection sensitivity (1 . . 5) remains unchanged on activation of the presence test. Sensitivity can be adjusted during the test.

The presence detector performs a restart after the end of the test mode.

### 2. Test-light

The light test is used to check the brightness switching value / set point value.

Activation	Control command test presence «On» with the «SendoPro 868-A» management remote control A telegram via bus object (52) The test light can always be activated
End	With subsequent restart: Control command test light «Off» with the «SendoPro 868-A» management remote control or with «theSenda P» installation remote control, button ↻ (Reset). OFF telegram via bus object (52) Mains failure and thus power up Automatically according to the time set with the ETS Without restart: Activation of test presence with the «SendoPro 868-A» management more remote control or «theSenda P».

LED display	Description
Flashing, 5 s off 0.3 s On	The LED flashes as long as the light test is active.

### Test response

The presence detector responds 100 % like in normal operation, only the reaction to bright/dark is faster. This makes it possible to test the brightness threshold and the adaptive response. The control is also faster. All selected functions and parameters remain unchanged.

### Commands and adjustable parameters

In the light test mood, the following commands are possible with the «SendoPro 868-A» management remote control:

- End light test
- Activate presence test
- Change brightness switching value / set point value channel C1, and C2 light

The presence detector performs a reset after the end of the test mode.



Do not use a torch to switch the presence detector. The presence detector will teach-in this and thereby distort the adaptive light thresholds and hysteresis values. In order to simulate this behaviour, the area below the presence detector should be illuminated or the blinds operated. Reactivate the light test for a new test.

## Troubleshooting

Fault	Cause
Light does not switch on or switches off if presence is detected and in darkness	Lux value is set too low; detector set on semi-automatic; light was switched off manually via push button or with remote control; person not within detection area; obstruction(s) interrupting detection; time delay set too short.
Light stays on when someone is present despite sufficient brightness	Lux value is set too high; light was recently switched on manually via push button or by remote control (wait 30 min during switching operation); detector is in test mode.
Light does not switch off and/or light switches on spontaneously when no one is present	Wait for time delay (self-learning); thermal sources of interference in the detection area: fan heaters, incandescent lamps/halogen spotlights, moving objects (e.g. curtains hanging in an open window).
Error flashing (3 x per second)	Self-test error; Invalid parameter values in the detector (see KNX-PlanoSpot manual chapter Parameter settings at Download). Device not functioning properly!

## LED display

LED	Description
Flashing at one second intervals	The presence detector is in the start-up phase.
Flickering for 2 s	The command sent from the remote control via infrared was accepted by the presence detector.
Lighting up briefly	The command sent from the remote control via infrared was rejected by the presence detector. The command is not valid. Check the selected detector type or parameters on the SendoPro.
Error flashing (3x s)	Error flashing; The presence detector has found an error.
Flashing, 5 s off 0.3 s On	The presence detector is in light test mode.
Lights up or flickers irregularly	The presence detector is in the presence test mode. The LED displays detection of movement.

## Dimensional diagrams

### PlanoSpot 360 KNX S

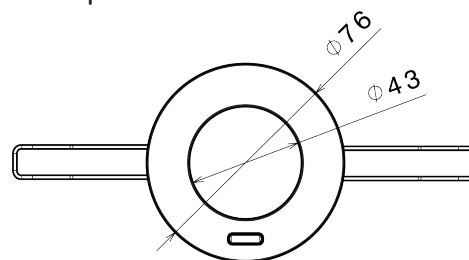

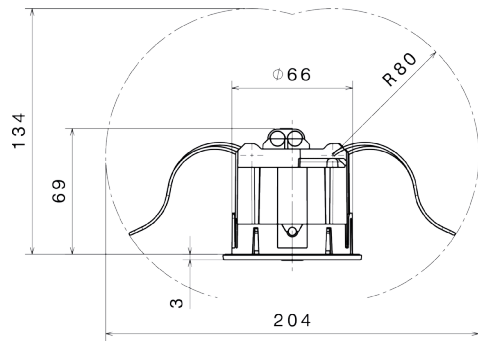

Back box 75 A

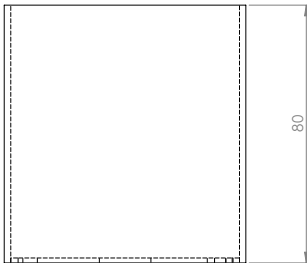
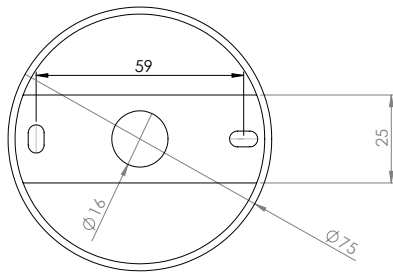

## 11. Technical data

Operating voltage	Bus voltage KNX, max. 30 V
Power consumption	approx. 8 mA / 9 mA with LED on
Type of installation	Installation in false ceilings
Recommended installation height	2.0 – 3.0 m (minimum height > 1.7 m)
Detection area horizontal vertical	360° 120°
Maximum range	8 x 8 m (Inst. ht. 3.0 m) / 64 m <sup>2</sup> moving 4.5 x 4.5 m (Inst. ht. 3.0 m) / 20 m <sup>2</sup> seated
Brightness switching value / set point value setting range	approx. 10 – 3000 lux
Lighting time delay	30 s – 60 min.
Presence time delay	10 s – 120 min.
Presence switch-on delay	10 s – 30 min / inactive
Standby dimming value	1 – 25 % of the lamp output
Stand-by time	30 s – 60 min / inactive / permanently on
All settings are remotely configurable	see KNX manual
Connection type	Plug-in terminals, type WAGO 243
Protection rating	IP 20
Ambient temperature	0 °C – 50 °C
CE Declaration of Conformity	This device conforms to the safety regulations of the EMC directive 2014/30/EC
RCM compliance	This device is compliant with the ACMA guidelines

## 12. Accessories

SendoPro 868-A  
Item No.: 9070675

Details > [www.theben.de](http://www.theben.de) / [www.theben-hts.ch](http://www.theben-hts.ch)



theSenda P  
Item No.: 9070910

Details > [www.theben.de](http://www.theben.de) / [www.theben-hts.ch](http://www.theben-hts.ch)



theSenda S  
Item No.: 9070911

Details > [www.theben.de](http://www.theben.de) / [www.theben-hts.ch](http://www.theben-hts.ch)



Plano Cover 76 WH  
Optional (cover white)  
Item no: 9070976

Plano Cover 76 BK  
(cover black)  
Item no: 9070977

Plano Cover 76 SR  
(cover silver)  
Item no: 9070978

Back box 75A WH  
Item No.: 9070949

Details > [www.theben.de](http://www.theben.de) / [www.theben-hts.ch](http://www.theben-hts.ch)

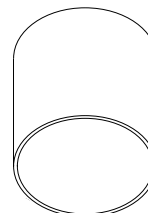



AP-frame 75A BK  
Item No.: 9070950  
[Details > www.theben.de/](http://www.theben.de/) [www.theben-hts.ch](http://www.theben-hts.ch)

AP-frame 75A SR  
Item No.: 9070951  
[Details > www.theben.de/](http://www.theben.de/) [www.theben-hts.ch](http://www.theben-hts.ch)

## Product overview

Type of installation	Channel	Colour	Type	Item number
Ceiling installation	3 Light   2 HVAC	White	PlanoSpot 360 KNX S DE WH	2039300

## Guarantee

ThebenHTS presence detectors are manufactured with the utmost care and using state-of-the-art technology and are quality-tested. ThebenHTS AG therefore guarantees perfect operation when used correctly. Should a fault occur, however, ThebenHTS AG will fulfil the guarantee within the scope of the general terms and conditions.

Please note in particular:

- that the guarantee period lasts 24 months from the date of manufacture.
- that the guarantee is invalidated if you, or a third party, make changes or undertake repairs to the devices.
- that, insofar as the presence detectors are connected to a software-controlled system, the guarantee for this connection is only valid when the indicated interface specification is complied with.

We undertake to repair or replace as quickly as possible all components of the delivered device that have become defective or unusable through demonstrably poor material, faulty construction or incomplete delivery up to the end of the guarantee period.

## Returns

In the event of a guarantee claim, please return the device to the relevant dealer together with the delivery note and a brief description of the fault.

## Industrial property rights

The design as well as hardware and software of these devices are protected by copyright.

## 13. Contact

### Switzerland

Theben HTS AG  
Im Langhag 7b  
8307 Effretikon  
SWITZERLAND  
Phone +41 52 355 17 00  
Fax +41 52 355 17 01

### Hotline

Phone +41 52 355 17 27  
[support@theben-hts.ch](mailto:support@theben-hts.ch)  
[www.theben-hts.ch](http://www.theben-hts.ch)

### All countries except Switzerland

### Theben AG

Hohenbergstrasse 32  
72401 Haigerloch  
GERMANY  
Phone: +49474 692-0  
Fax: +497474 692-150

### Hotline

Phone: +49 7474 692-369  
[hotline@theben.de](mailto:hotline@theben.de)  
[www.theben.de](http://www.theben.de)